

ROOFTOP

TECHNICAL GUIDE **Rooftop Cooling Only + Gas Heating** **Models DIG 090 to 300**

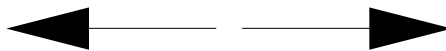
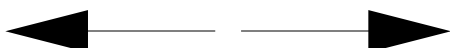

List of Contents

	<i>Page</i>
1 - Description	4
2 - Product Nomenclature	4
3 - Features	5
3.1 - Convertible airflow design.....	5
3.2 - Wide range of indoor airflows.....	5
3.3 - Full perimeter base rails.....	5
3.4 - Service connections.....	5
3.5 - Simple control circuit.....	5
3.6 - Multiple refrigerant circuits.....	5
3.7 - Durable construction.....	5
3.8 - Low noise.....	5
3.9 - Compressors.....	5
3.10 - System protection.....	5
3.11 - Gas burner.....	5
3.12 - Air filters.....	5
3.13 - Electrical control box.....	5
4 - Technical Specifications	6
5 - Electrical Data	6
6 - Indoor fan characteristics	7
7 - Operating Limits	7
8 - Accessories	7
8.1 - Dual input electronic enthalpy economizers.....	7
8.2 - Motorized outdoor air intake damper.....	7
8.3 - Barometric relief/fixed outdoor air intake damper assembly (models 090 to 150).....	8
8.4 - Fixed outdoor air intake damper (models 180-240-300).....	8
8.5 - Barometric relief damper (models 180-240-300).....	8
8.6 - Anti-recycle timers.....	8
8.7 - Low ambient kit.....	8
8.8 - Roof curbs.....	8
8.9 - High speed drive.....	8
8.10 - Propane conversion kit.....	8
8.11 - Clogged filter pressure switch.....	8
8.12 - Smoke detection.....	8
9 - Capacity Ratings	9
9.1 - Cooling Capacities.....	9
9.2 - Gas Heat Application Data.....	14
10 - Blower Performance	14
11 - Indoor coil pressure drops	17
12 - Accessory Static Resistances	17
13 - Dimensions	18
14 - Roof Curb	22
14.1 - Roof Curb Dimensions.....	22
14.2 - Unit and Curb Application.....	23
15 - Safety	23
16 - Inspection	24
17 - Positioning	24
17.1 - Location.....	24
17.2 - Rigging and Handling.....	24



List of Contents

	Page
18 - Lifting and Handling	25
19 - Installation	25
19.1 - Ductwork.....	25
19.2 - Condensate Drain.....	25
19.3 - Filters.....	26
19.4 - Barometric relief/fixed outdoor air intake damper assembly.....	26
19.5 - Fixed outdoor air intake damper.....	27
19.6 - Optional economiser rain hood (models 090-150).....	28
19.7 - Optional economiser rain hood (models 180-240-300).....	29
19.8 - Power exhaust damper and rain hood option (models 180-240-300).....	30
19.9 - Vent and combustion air hoods.....	31
19.10 - Gas piping.....	32
19.11 - Gas connection.....	32
19.12 - Gas piping recommendations.....	32
19.13 - Power wiring.....	33
19.14 - Electromechanical thermostat.....	33
19.15 - Non programmable electronic thermostat ART TH 002 (DSL 700).....	33
19.16 - Programmable thermostat.....	33
20 - Operation	34
20.1 - Preliminary operation.....	34
20.2 - Cooling sequence of operation (models 090-150).....	34
20.3 - Heating sequence of operation (models 090-150).....	34
20.4 - Cooling sequence of operation (models 180-240-300).....	34
20.5 - Heating sequence of operation (models 180-240-300).....	34
20.6 - Economizer with dual enthalpy sensor.....	35
20.7 - Enthalpy setpoint adjustment.....	35
20.8 - Economizer with exhaust fan option available with DIG 180-240-300.....	35
20.9 - Motorized outdoor air dampers.....	36
20.10 - Heat anticipator setpoint.....	36
20.11 - Pre-start check list (gas burner).....	36
20.12 - Post-start check list (gas).....	36
20.13 - Manifold gas pressure adjustment (models 090-120-150).....	36
20.14 - Manifold gas pressure adjustment (models 180-240-300).....	37
20.15 - Belt drive blower.....	37
20.16 - To check the supply air volume after the initial balancing has been completed (models 090 to 150).....	37
20.17 - To check the supply air volume after the initial balancing has been completed (models 180-240-300).....	38
21 - System Protections	38
21.1 - Lockout control.....	38
22 - Maintenance	39
22.1 - Filters.....	39
22.2 - Motors.....	39
22.3 - Outdoor coil.....	39
22.4 - Burner.....	39
22.5 - Cleaning flue passages and heating elements.....	39
23 - Fault Analysis	40
23.1 - General.....	40
23.2 - Probable fault causes and suggested corrective action.....	40

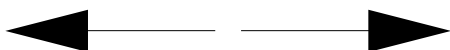

1 - Description

The DIG units are highly efficient single package air cooled air conditioners and gas heating units.

The DIG series includes 5 model sizes of cooling and gas heating. Sunline 2000 units are suitable for outdoor installation either on a roof or at ground level.

They are completely assembled, piped, wired and charged with refrigerant at the factory to provide one piece shipment and rigging, then quick and easy field installation.

Accessories

An extensive list of either factory installed or field fitted options are available to enhance the design flexibility of Sunline 2000.

- **Economiser control** - An advanced electronic enthalpy sensor system (dual) developed in collaboration with Honeywell to permit maximised reliability in non-mechanical cooling using outdoor air.
- **Motorised outdoor air systems.**
- **Fixed outdoor and barometric relief air damper.**
- **Side duct connections** : 25mm connection tabs replace the side discharge and return panels to facilitate the use of side return ducting with unit sizes 180, 240 and 300.

- **Low ambient controls** for operation down to -18°C ambient temperatures (not heat pump models).

- **Anti-recycle timers.**

- **Roof curb** - to enable building work on site to be completed quickly and easily. They provide a water-tight seal between the unit and the completed roof.

- **Alternative drive kits** for indoor air fan to meet a variety of air flow requirements on model 090 and above.

- **Propane conversion kit.**

- **Adjustable Clogged Filter pressure switch.**

- **Smoke detection** opens the outdoor air dampers and stops the unit. Delivered with an ionic detector and an "NF" approved electronics board.

- **Electromechanical Thermostat.**

- **Programmable Thermostat.**

N.B. : Please check with YORK which of the above are available as factory fitted or customer fitted options.

2 - Product Nomenclature

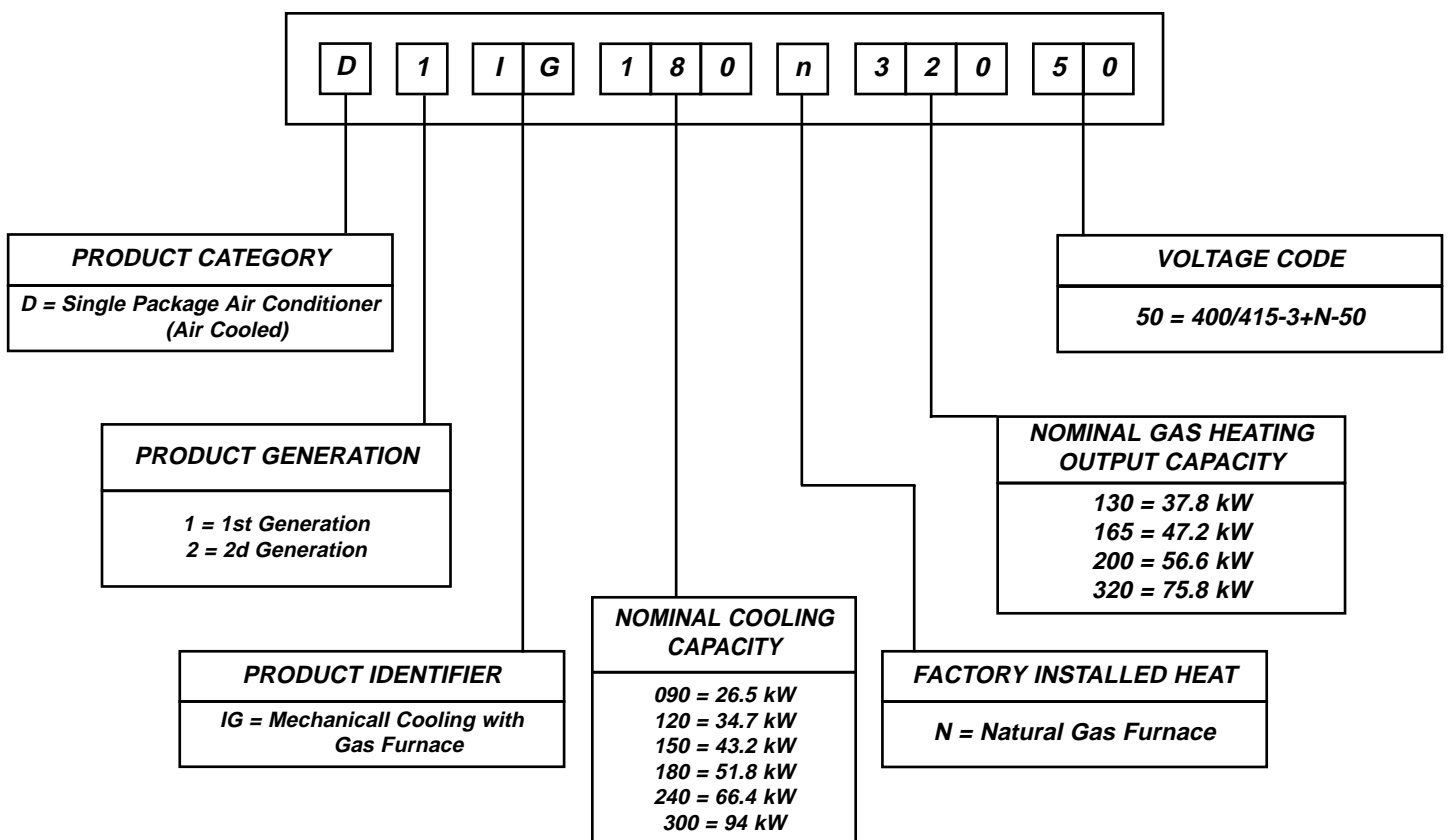

3 - Features

3.1 - Convertible airflow design

For maximum flexibility all models can be adapted for downward or horizontal airflow by simply removing two panels (either bottom or side) at the time of installation.

3.2 - Wide range of indoor airflows

All models operate over a wide range of design conditions. Each unit is equipped with belt drive fans with adjustable pitch pulleys to exactly match the airflow requirements.

3.3 - Full perimeter base rails

The permanently attached base rails provide a solid foundation for the entire unit and protect the unit during shipment.

The rails provide rigging holes so that an overhead crane can be used to position equipment on site.

3.4 - Service connections

Electric utility knockouts are provided in the base as well as the side of the units to enable single point power connections to be made with the minimum amount of field labour.

3.5 - Simple control circuit

A 24 V control circuit is system ready to match the optional YORK wall thermostat.

An additional set of pin connectors is also provided so that site commissioning and troubleshooting can be simplified by use of a YORK system analyser.

The electrical control box is not located in the compressor compartment so the access cover can be removed for servicing without affecting normal system operating pressures.

3.6 - Multiple refrigerant circuits

Twin circuits on models 090, 120, 150, 180, 240 ensure better control of space temperature, comfort level and better efficiency for minimum running cost.

3.7 - Durable construction

All of the units sheet metal parts are constructed of commercial grade (G90) galvanised sheet steel.

After fabrication, each part is thoroughly cleaned. External parts are then coated with zinc phosphate and finished with baked enamel to ensure a quality finish that will last for many years.

This approved coating system has passed the 250 hour, 20 % salt spray test as per ASTM Standard B117.

3.8 - Low noise

All YORK package air conditioners operate at extremely low sound level.

Compressors are mounted on vibration isolators.

Vertical discharge condenser fans direct sound upward and away from any surrounding structures.

3.9 - Compressors

Hermetic compressors with suction gas cooled motor and acoustic insulation of suction and discharge lines and external crankcase oil heater.

3.10 - System protection

Each refrigeration circuit is provided with the following protection devices as standard :

- HP and LP cut-out switches
- Suction line freeze-stat
- Liquid line filter drier
- Crankcase heater and internal compressor protection
- Compressor anti recycle timer.

3.11 - Gas burner

All gas heat models are built with two equal stages of capacity control. The burner includes a durable heat exchanger with aluminized steel tubes, a redundant gas valve, spark ignition, power venting, an ignition module for 100% shut-off and all of the safety controls required to meet the latest CE standards.

The gas supply piping can be routed into the heating compartment through a hole in the base pan of the unit or through a knockout in the piping panel on the front of the unit.

The unit is complete and ready to be connected on low pressure gas supply 20 mbar.

3.12 - Air filters

Units are fitted with 50 mm throwaway filter.

3.13 - Electrical control box

- Conform to standards EN60204-1 and 60439-1.
- Main switch with yellow red handle and interlocked door installed as standard.



4 - Technical Specifications

Models		DIG									
		090		120		150		180	240	300	
Capacities	Cooling	kW	26,5		34,7		43,2		51,8	66,4	94
		kcal/h	22 800		29 800		37 150		44 550	57 100	80 840
	Heating	Type of burner	N130	N165	N165	N200	N165	N200	N320	N320	N320
		kW	37,8	47,2	47,2	56,6	47,2	56,6	75,8	75,8	75,8
		kcal/h	32 500	40 600	40 600	48 800	40 600	48 800	65 200	65 200	65 200
Compressor	Type	Reciprocating									
Refrigerant		R22									
Number of circuits		2									
Power supply	V/Ph/Hz	380 - 415 / 3 + N / 50									
Power consumption*	kW	8,2	9,8	13,5	15,2	20,4	29,4				
Running/Starting current	A	25,6/72	29,6/76	42,8/111	46,7/151	60,1/151	88/170				
Indoor air flow	m ³ /h	5 100	6 800	8 800	10 200	13 600	17 100				
	CFM	3 000	4 000	5 200	6 000	8 000	10 000				
Static pressure	Pa	310	440	400	430	390	550				
Dimensions	H (mm)	860	1 013	1216	1 235	1 337	1 337				
	W (mm)	2 560	2 560	2 560	3 181	3 461	3 461				
	D (mm)	1 803	1 803	1 803	2 337	2 337	2 337				
Net weight	kgs	498	553	720	975	1 066	1 238				
The Nominal Cooling Capacity is based on : Indoor Air Temp. 27°C DB/19°C WB Outdoor Air Temp. 35°C DB											

* Without indoor fan

These capacities are gross ratings. For net capacity, correct with the heat of the supply air blower motor. Refer to the appropriate Blower Performance Table for the kW of the supply air blower motor.

5 - Electrical Data

Model	Power supply	Compressors n°1 & n°2		Cond. fan motor		Supply air blower motor		Total unit current AMPS	Max. fuse size AMPS
		RLA each	LRA each	HP each	FLA each	HP	FLA		
090	380-415/3/50	8.3	69	1.2	1.9	2	3.9	25.6	35
120	380-415/3/50	9.6	73	1.2	1.9	3	5.1	29.6	35
150	380-415/3/50	14.1	108	1.2	1.9	5	8.2	42.8	50

Model	Power supply	Compressors n°1 & n°2		Cond. fan motors n°1 & n°2		Supply air blower motor		Minimum circuit current AMPS	Max. time delay fuse size AMPS
		RLA each	LRA each	HP each	FLA each	HP	FLA		
180	380-415/3/50	19.2/9.6	146/73	1	2.4	3.73	8.2	46.7	63
240	380-415/3/50	19.2	146	1	2.4	5.6	12	60.1	63
300	380-415/+3N/50	19.2 x 3	146	0.7	2.4	7.4	19	86.2	100

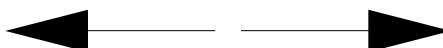

6 - Indoor Fan Characteristics

Units assembled in the USA (colour : "Desert sand")	Model	Blower range (RPM)	Motor ¹			Adjustable motor pulley ²			Fixed blower pulley			Belt		
			kW (hp)	Frame Size	Eff. (%)	Pitch dia. (mm/in)	Bore (mm/in)	Designation	Pitch dia. (mm/in)	Bore (mm/in)	Designation	Pitch length (mm/in)	Designation	Qty
	090	950-1230	1.5	145T	84	86-112	22.2	1VM50	132	25	AK56	1227	A47	1
	120	880-1120	2.2	182T	81	94-119	28.6	1VP50	155	25	BK67	1417	BX54	1
	150	960-1160	3.7	184T	84	125-150	28.6	1VP62	188	25	BK80	1519	BX58	1
Std. drive	180	845-1040	3.7	184T	84	109-135	29	1VP56	188	25	BK80	1773	BX68	1
	240	765-905	5.5	213T	87	140-165	35	1VP68	264	30	BK110	2103	BX81	1
High speed drive	180	1030-1240	3.7	184T	84	124-150	29	1VP62	175	25	BK75	1773	BX68	1
	240	895-1080	5.5	213T	87	147-178	35	1VP75	239	30	BK100	2103	BX81	1

Units assembled in Europe (colour : white RAL9002)	Model	Blower range (RPM)	Motor ¹		Adjustable motor pulley ²		Fixed blower pulley		Belt		
			kW (hp)	Frame Size	Pitch dia. (mm/in)	Bore (mm/in)	Pitch dia. (mm/in)	Bore (mm/in)	Pitch length (mm/in)	Designation	Qty
	090	950-1230	1.5	90L	86-112	24	132	25	1 240	BX-47	1
	120	880-1120	2.2	100L	94-119	28	155	25	1 440	BX-55	1
	150	960-1160	3.7	112M	125-150	28	188	25	1 590	BX-61	1
Std drive	180	845-1040	3.7	112M	109-135	28	188	25	1 790	BX-69	1
	240	765-905	5.5	132S	140-165	38	264	25	2 123	BX-82	1
High speed drive	180	1030-1240	3.7	112M	124-150	28	175	25	1 790	BX-69	1
	240	895-1080	5.5	132S	147-178	38	239	25	2 123	BX-82	1
	300	980-1170	7.5	132M	152-190	38	235	35	2 123	BX82	2

¹ All motors are totally enclosed, fan cooled (TEFC), 1450 RPM with solid bases and a 1.15 service factor.

² Do NOT close this pulley below the minimum number of turns open.

7 - Operating Limits

Model		090	120	150	180	240	300	
Voltage Variation Min./Max.	380-415/III/50	342-457						
Wet bulb temperature (°C) of air on evaporator coil Min./Max.		14/22						
Dry bulb temperature (°C) of air on condenser coil Min./Max.		7/52			-4/52			

8 - Accessories

8.1 - Dual input electronic enthalpy economizers

Includes a slide-in / plug-in damper assembly with fully modulating spring-return motor actuator capable of introducing up to 100% outdoor air with nominal 1% leakage type dampers.

This enthalpy system contains one sensor that monitors the outdoor air and one sensor that monitors the return air. The logic module compares these two values and modulates the dampers providing the maximum efficiency of economizer system.

The rain hood is painted to match the basic unit and must be field-assembled before installing.

All of the hood components, including the filters, the gasketing and the hardware for assembling are packaged and located within the unit filter section (see figures page 5).

8.2 - Motorized outdoor air intake damper

Includes a slide-in / slug-in damper with a 2-position, spring-return motor actuator which opens to some pre-set position whenever the supply air blower is operating and will drive fully closed when the blower shuts down.

The rain hood is the same than the economizers.

8 - Accessories (Cont'd)

8.3 - Barometric relief/fixed outdoor air intake damper assembly (Models 090 to 150)

The device is available as standard on model sizes 090, 120, 150. This damper assembly is shipped inside of the return air compartment.

It serves as a barometric relief damper on units with economiser or as a fixed outdoor air intake damper on units less economiser.

On units with bottom return, install the damp assembly over the opening in the side return air duct cover.

The damper can be adjusted to allow up to 25% outdoor air to enter the unit's return air section. This same device can be used for barometric relief on units with economizer.

On units with economiser, adjust the damper to the desired air exhaust flow opening by moving the damper bracket (inside of the hood) to one of the 3 positions provided.

Position 1 will allow approximately 25% recirculated air flow, position 2 approximately 15% and position 3 approximately 10%. A screw on each side of the hood secures the bracket in place.

8.4 - Fixed outdoor air intake damper (Models 180-300)

A fixed outdoor air intake assembly will be shipped in the return air compartment of all units ordered without an economizer or motorized outdoor air damper option.

The assembly includes a rain hood with a damper that can be set for 10, 15 or 25% outdoor air. With bottom duct connections, the intake damper assembly should be mounted over the opening in the return air panel. With horizontal ductwork, it should be mounted on the return air duct.

Adjusting the damper to the desired air flow may be done before mounting the hood into position or (after installation) by removing the front hood panel or the screen on the bottom of the hood.

Damper baffle in position 1 will allow approximately 10% recirculated air flow, position 2 approximately 15% and, to allow approximately 25%, remove the damper baffle.

8.5 - Barometric relief damper (Models 180-300)

This damper accessory can be used to relieve internal air pressure on units with an economizer but no power exhaust.

This accessory includes a rain hood, a bird screen and a fully assembled damper. With bottom duct connections, the damper should be mounted over the opening in the return air panel. With horizontal ductwork, the accessory should be mounted on the return air duct.

8.6 - Anti-recycle timers

Two solid state timers prevent the compressors from short-cycling. Once a compressor is de-energized, it will remain de-energized for approximately five minutes.

8.7 - Low ambient kit

Standard single package air conditioners are only designed to operate at ambient temperatures down to 7 or -4°C (depending the size). With this accessory, the unit operate safely at ambient temperatures down to -18°C.

All components, including condenser motor, temperature control, wires and mounting hardware are supplied in each accessory.

8.8 - Adjustable or non adjustable roof curbs

Roof curbs 356mm high provide a water-tight seal between the unit and the finished roof. These full perimeter curbs are shipped knocked-down for field assembly.

They're designed to fit inside the base rails of the unit and include both a wood nailing strip and duct hanger supports.

Ducts can be installed into the curb from the roof. All electrical wiring connections can be made inside the curb.

Adjustable roof curbs have the same characteristics. They enable installation of the rooftop units on sloping roofs. The maximum gradient is between 7 and 9% depending on the size of the unit.

8.9 - High speed drive

A smaller blower pulley and a larger motor pulley (including a replacement belt) increase the speed of the supply air blower for applications with a higher airflow and/or static pressure requirement.

This accessory is only available on size 180, 240 and 300.

8.10 - Propane conversion kit

Burner orifices, pilot orifices and gas valve parts are provided to convert a natural gas furnace to propane. The propane pressure supply must be 37mbar.

8.11 - Clogged filter pressure switch

It permits to "deliver" a dry contact when the filters are clogged. The setting range adjustable is: 20-300 Pa. It is made of polycarbonate and is dripproof IP54.



Fig. 1 - Clogged filter pressure switch

8.12 - Smoke detection

This option contains two main components:

- 1 - An ionic detector in accordance with standard 950-11-85.
- 2 - An electronic board in accordance with standard 961-09-89.

They are fitted in the return air section after the air filters and when smoke is detected, the outdoor air damper opens and the unit stops. Manual reset inside the unit enables roof-top to be restarted.



Fig. 2 - Smoke detection

9 - Capacity Ratings

9.1 - Cooling capacities

9.1.1 - DIG 090

Air On Evaporator Coil		Temperature of air on condensing coil															
		27°C					35°C					46°C					
		Total Cap. kW	Power Input kW	Sensible Capacity kW			Total Cap. kW	Power Input kW	Sensible Capacity kW			Total Cap. kW	Power Input kW	Sensible Capacity kW			
Entering Dry Bulb °C				Entering Dry Bulb °C					Entering Dry Bulb °C								
m³/h	WB °C																
6 370				32	30	28											
	23	34.2	7.7	26.2	22.6	19	30.9	8.5	25.3	21.8	18.2	26.8	9.6	23.4	19.8	16.2	
	21	32.2	7.6	30.1	26.5	22.9	29.1	8.3	29	25.4	21.9	25.2	9.4	25.2	23.6	20	
	19	30.2	7.5	30.2	30.2	26.8	27.3	8.2	27.3	27.3	25.5	23.7	9.2	23.7	23.7	23.7	
	17	29.1	7.5	29.1	29.1	29.1	26.6	8.2	26.6	26.6	26.6	22.7	9.1	22.7	22.7	22.7	
	15	28.1	7.4	28.1	28.1	28.1	26	8.1	26	26	26	21.8	9	21.8	21.8	21.8	
					26	24	22										
	23	34.2	7.7	15.5	11.9	-	30.9	8.5	14.6	11	-	26.8	9.6	12.6	9.1	-	
	21	32.2	7.6	19.3	15.8	12.2	29.1	8.3	18.3	14.7	11.1	25.2	9.4	16.4	12.8	9.2	
	19	30.2	7.5	23.2	19.6	16	27.3	8.2	22	18.4	14.8	23.7	9.2	20.1	16.6	13	
	17	29.1	7.5	25.8	22.2	18.6	26.6	8.2	23.9	20.3	16.8	22.7	9.1	20.9	17.3	13.8	
15	28.1	7.4	26.3	22.7	19.1	26	8.1	24.2	20.7	17.1	21.8	9	20	16.4	12.8		
5 110				32	30	28											
	23	33.2	7.7	23	20	17.1	30	8.5	22	19	16.1	26.8	9.5	20.4	17.5	14.6	
	21	31.3	7.6	26.5	23.5	20.6	28.3	8.3	25.3	22.3	19.4	25.2	9.3	23.8	20.9	18	
	19	29.4	7.5	29.4	27	24.1	26.5	8.2	26.5	25.6	22.7	23.7	9.1	23.7	23.7	21.4	
	17	28.3	7.5	28.3	28.3	26.4	25.9	8.2	25.9	25.9	24.4	22.7	9	22.7	22.7	22.3	
	15	27.3	7.4	27.3	27.3	27.3	25.3	8.1	25.3	25.3	25.3	21.8	8.9	21.8	21.8	21.8	
					26	24	22										
	23	33.2	7.7	14.1	11.2	-	30	8.5	13.2	10.2	-	26.8	9.5	11.6	8.7	-	
	21	31.3	7.6	17.6	14.7	11.8	28.3	8.3	16.4	13.5	10.6	25.2	9.3	15	12.1	9.2	
	19	29.4	7.5	21.1	18.2	15.3	26.5	8.2	19.7	16.8	13.8	23.7	9.1	18.4	15.5	13	
	17	28.3	7.5	23.5	20.5	17.6	25.9	8.2	21.5	18.5	15.6	22.7	9	19.4	16.4	13.8	
15	27.3	7.4	25.8	22.8	19.9	25.3	8.1	23.2	20.3	17.3	21.8	8.9	20.3	17.3	12.8		
3 820				32	30	28											
	23	29.7	7.7	18.4	16.2	13.9	26.9	8.5	17.6	15.3	13.1	24.3	9.4	16.4	14.1	11.9	
	21	28	7.5	21.3	19	16.8	25.3	8.3	20.3	18	15.8	22.8	9.2	19.2	16.9	14.7	
	19	26.3	7.4	24.1	21.9	19.7	23.7	8.2	23	20.7	18.5	21.4	9	21.4	19.7	17.5	
	17	25.3	7.4	25.3	23.8	21.6	23.2	8.2	23.2	22.2	19.9	20.6	8.9	20.6	20.5	18.3	
	15	24.4	7.3	24.4	24.4	23.5	22.6	8.1	22.6	22.6	21.3	19.7	8.8	19.7	19.7	19	
					26	24	22										
	23	29.7	7.7	11.7	9.4	-	26.9	8.5	10.9	8.6	-	24.3	9.4	9.7	7.4	-	
	21	28	7.5	14.5	12.3	10.1	25.3	8.3	13.5	11.3	9.1	22.8	9.2	12.5	10.2	8	
	19	26.3	7.4	17.4	15.2	12.9	23.7	8.2	16.2	14	11.8	21.4	9	15.3	13	10.8	
	17	25.3	7.4	19.3	17.1	14.8	23.2	8.2	17.7	15.4	13.2	20.6	8.9	16	13.8	11.5	
15	24.4	7.3	21.2	19	16.7	22.6	8.1	19.1	16.9	14.6	19.7	8.8	16.8	14.6	12.3		

These capacities are gross ratings. For net capacity, correct with the heat of the supply air blower motor.

Refer to the appropriate Blower performance Table for the kW of the supply air blower motor.

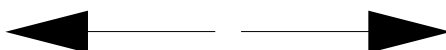

9 - Capacity Ratings (Cont'd)

9.1.2 - DIG 120

Air On Evaporator Coil		Temperature of air on condensing coil															
		27° C					35° C					46° C					
		Total Cap. kW	Power Input kW	Sensible Capacity kW			Total Cap. kW	Power Input kW	Sensible Capacity kW			Total Cap. kW	Power Input kW	Sensible Capacity kW			
m ³ /h	WB °C	Entering Dry Bulb °C			Total Cap. kW	Power Input kW	Entering Dry Bulb °C			Total Cap. kW	Power Input kW	Entering Dry Bulb °C					
		32	30	28			32	30	28			32	30	28			
8 500	23	43.4	9.3	35	30.6	26.2	40.4	10.3	31.7	27.3	22.9	35.8	11.6	30.4	26	21.6	
	21	41	9.2	39.4	35	30.6	38.1	10.1	36.7	32.3	27.9	33.8	11.3	33.8	30.5	26.1	
	19	38.6	9.1	38.6	38.6	35.1	35.9	9.9	35.9	35.9	32.9	31.7	11.1	31.7	31.7	30.5	
	17	37.3	8.9	37.3	37.3	37.3	34.7	9.8	34.7	34.7	34.7	31	11	31	31	31	
	15	36	8.8	36	36	36	33.6	9.7	33.6	33.6	33.6	30.2	10.9	30.2	30.2	30.2	
					26	24	22			26	24	22			26	24	22
	23	43.4	9.3	21.8	17.4	-	40.4	10.3	18.5	14.1	-	35.8	11.6	17.2	12.9	-	
	21	41	9.2	26.3	21.9	17.5	38.1	10.1	23.5	19.1	14.7	33.8	11.3	21.7	17.3	12.9	
	19	38.6	9.1	30.7	26.3	21.9	35.9	9.9	28.5	24.1	19.7	31.7	11.1	26.1	21.7	17.3	
	17	37.3	8.9	33.7	29.3	24.9	34.7	9.8	30.4	26	21.6	31	11	27.5	23.1	18.7	
	15	36	8.8	33.8	29.4	25	33.6	9.7	31.4	27	22.6	30.2	10.9	28	23.6	19.2	
	6 800				32	30	28			32	30	28			32	30	28
		23	42.1	9.2	30.1	26.4	22.7	39.1	10.2	28	24.3	20.5	34.3	11.5	26.6	22.9	19.2
		21	39.8	9.1	34	30.3	26.6	36.9	10	32.5	28.8	25.1	32.4	11.2	30.6	26.9	23.2
19		37.4	9	37.4	34.2	30.5	34.7	9.8	34.7	33.3	29.6	30.4	10.9	30.4	30.4	27.1	
17		36.2	8.9	36.2	36.2	33	33.6	9.7	33.6	33.6	31.3	29.7	10.9	29.7	29.7	28.3	
15		35	8.8	35	35	35	32.5	9.6	32.5	32.5	32.5	28.9	10.8	28.9	28.9	28.9	
					26	24	22			26	24	22			26	24	22
23		42.1	9.2	19	15.3	-	39.1	10.2	16.8	13.1	-	34.3	11.5	15.5	11.8	-	
21		39.8	9.1	22.9	19.2	15.4	36.9	10	21.3	17.6	13.9	32.4	11.2	19.4	15.7	12	
19		37.4	9	26.8	23	19.3	34.7	9.8	25.9	22.2	18.4	30.4	10.9	23.4	19.7	16	
17		36.2	8.9	29.3	25.6	21.9	33.6	9.7	27.6	23.9	20.2	29.7	10.9	24.6	20.9	17.2	
15		35	8.8	31.9	28.2	24.5	32.5	9.6	29.3	25.6	21.9	28.9	10.8	25.8	22.1	18.4	
5 110					32	30	28			32	30	28			32	30	28
		23	38.7	9	25.4	22.5	19.6	35.5	10.1	22.6	19.7	16.9	32	11.2	21.8	18.9	16
	21	36.5	8.9	28.7	25.9	23	33.5	9.9	26.4	23.5	20.6	30.2	10.9	25.1	22.2	19.3	
	19	34.4	8.8	32.1	29.2	26.4	31.5	9.7	30.1	27.2	24.3	28.3	10.6	28.3	25.6	22.7	
	17	33.2	8.7	33.2	31.5	28.6	30.5	9.6	30.5	28.6	25.7	27.7	10.6	27.7	26.6	23.7	
	15	32.1	8.6	32.1	32.1	30.9	29.5	9.5	29.5	29.5	27.2	27	10.5	27	27	24.7	
					26	24	22			26	24	22			26	24	22
	23	38.7	9	16.7	13.8	-	35.5	10.1	14	11.1	-	32	11.2	13.1	10.3	-	
	21	36.5	8.9	20.1	17.2	14.3	33.5	9.9	17.7	14.8	11.9	30.2	10.9	16.5	13.6	10.7	
	19	34.4	8.8	23.5	20.6	17.7	31.5	9.7	21.4	18.6	15.7	28.3	10.6	19.8	16.9	14	
	17	33.2	8.7	25.7	22.8	20	30.5	9.6	22.9	20	17.1	27.7	10.6	20.8	17.9	15.1	
	15	32.1	8.6	28	25.1	22.2	29.5	9.5	24.3	21.4	18.5	27	10.5	21.8	19	16.1	

These capacities are gross ratings. For net capacity, correct with the heat of the supply air blower motor. Refer to the appropriate Blower performance Table for the kW of the supply air blower motor.

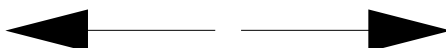

9 - Capacity Ratings (Con'd)

9.1.3 - DIG 150

Air On Evaporator Coil		Temperature of air on condensing coil															
		27°C					35°C					46°C					
		Total Cap. kW	Power Input kW	Sensible Capacity kW			Total Cap. kW	Power Input kW	Sensible Capacity kW			Total Cap. kW	Power Input kW	Sensible Capacity kW			
m ³ /h	WB °C	Entering Dry Bulb °C															
		32	30	28	32	30	28	32	30	28	32	30	28	32	30	28	
6 500	23	47.9	12.4	33	29	26	46.2	13.9	31	27	23	40.5	15.3	28	25	21	
	21	45.7	12.2	37	33	30	43.2	13.5	35	31	28	37.9	14.9	33	29	25	
	19	43.4	11.9	41	37	34	40.3	13.2	40	36	32	35.4	14.5	35	34	30	
	17	41.6	11.8	42	40	37	39	13	39	39	35	34.4	14.4	34	34	32	
	15	39.7	11.6	40	40	40	37.6	12.9	38	38	37	33.5	14.3	34	34	33	
					26	24	22			26	24	22			26	24	22
	23	47.9	12.4	22	18	-	46.2	13.9	19	15	-	40.5	15.3	17	13	-	
	21	45.7	12.2	26	22	18	43.2	13.5	24	20	16	37.9	14.9	22	18	14	
	19	43.4	11.9	30	26	22	40.3	13.2	29	25	21	35.4	14.5	26	22	19	
	17	41.6	11.8	33	29	25	39	13	31	27	23	34.4	14.4	28	24	20	
15	39.7	11.6	36	32	28	37.6	12.9	33	30	26	33.5	14.3	29	26	22		
8 640				32	30	28			32	30	28			32	30	28	
	23	51.7	12.4	39	34	29	49.4	14	36	31	26	43.1	15.5	34	29	24	
	21	49.3	12.2	44	39	34	46.3	13.6	41	37	32	40.4	15.1	39	34	29	
	19	46.9	12	47	43	39	43.2	13.2	43	42	37	37.6	14.7	38	38	35	
	17	44.9	11.8	45	45	42	41.7	13.1	42	42	40	36.6	14.6	37	37	36	
	15	42.8	11.6	43	43	43	40.3	13	40	40	40	35.7	14.5	36	36	36	
					26	24	22			26	24	22			26	24	22
	23	51.7	12.4	24	20	-	49.4	14	22	17	-	43.1	15.5	19	14	-	
	21	49.3	12.2	29	24	19	46.3	13.6	27	22	17	40.4	15.1	24	20	15	
	19	46.9	12	34	29	24	43.2	13.2	32	27	23	37.6	14.7	30	25	20	
17	44.9	11.8	37	32	27	41.7	13.1	35	30	25	36.6	14.6	31	27	22		
15	42.8	11.6	40	36	31	40.3	13	38	33	28	35.7	14.5	33	28	24		
10 800				32	30	28			32	30	28			32	30	28	
	23	53	12.9	45	39	33	50.7	14.2	42	36	30	44.2	15.7	39	33	27	
	21	50.6	12.7	50	44	38	47.5	13.8	47	42	36	41.4	15.3	41	39	33	
	19	48.1	12.4	48	48	44	44.3	13.5	44	44	42	38.6	14.9	39	39	39	
	17	46	12.2	46	46	46	42.8	13.4	43	43	43	37.6	14.8	38	38	38	
	15	43.9	12	44	44	44	41.3	13.2	41	41	41	36.6	14.7	37	37	37	
					26	24	22			26	24	22			26	24	22
	23	53	12.9	27	21	-	50.7	14.2	24	18	-	44.2	15.7	21	15	-	
	21	50.6	12.7	33	27	21	47.5	13.8	30	24	18	41.4	15.3	27	21	15	
	19	48.1	12.4	38	32	26	44.3	13.5	36	30	24	38.6	14.9	33	27	21	
17	46	12.2	42	36	30	42.8	13.4	39	33	27	37.6	14.8	35	29	23		
15	43.9	12	41	35	29	41.3	13.2	38	32	27	36.6	14.7	34	28	22		

These capacities are gross ratings. For net capacity, correct with the heat of the supply air blower motor.
Refer to the appropriate Blower performance Table for the kW of the supply air blower motor.

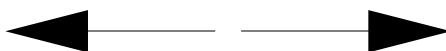

9 - Capacity Ratings (Cont'd)

9.1.4 - DIG 180

Air On Evaporator Coil		Temperature of air on condensing coil															
		27° C					35° C					46° C					
		Total Cap. kW	Power Input kW	Sensible Capacity kW			Total Cap. kW	Power Input kW	Sensible Capacity kW			Total Cap. kW	Power Input kW	Sensible Capacity kW			
m ³ /h	WB °C	Entering Dry Bulb °C															
		32	30	28	32	30	28	32	30	28	32	30	28				
7 560	23	57.1	14.3	37	32	28	51.9	15.6	36	31	27	46.5	17.5	33	29	24	
	21	53.6	14	43	38	33	48.9	15.3	41	37	32	44.4	17	39	34	30	
	19	50.1	13.6	48	44	39	45.9	14.9	46	42	38	42.3	16.4	42	40	35	
	17	48.7	13.6	49	47	42	44.7	14.8	45	45	40	40.9	16.4	41	41	36	
	15	47.4	13.5	47	47	45	43.6	14.7	44	44	43	39.5	16.4	40	40	38	
					26	24	22			26	24	22			26	24	22
	23	57.1	14.3	23	19	-	51.9	15.6	22	17	-	46.5	17.5	19	15	-	
	21	53.6	14	29	24	19	48.9	15.3	27	23	18	44.4	17	25	20	16	
	19	50.1	13.6	34	30	25	45.9	14.9	33	28	24	42.3	16.4	31	26	21	
	17	48.7	13.6	37	33	28	44.7	14.8	35	31	26	40.9	16.4	32	27	22	
15	47.4	13.5	40	36	31	43.6	14.7	38	33	29	39.5	16.4	33	28	24		
10 080				32	30	28			32	30	28			32	30	28	
	23	61.5	14.5	46	40	34	56.3	15.9	44	38	32	49.4	17.8	41	35	29	
	21	57.7	14.2	53	46	40	53.1	15.6	51	44	38	47.2	17.2	47	42	36	
	19	53.9	13.9	54	53	47	49.8	15.2	50	50	45	44.9	16.6	45	45	42	
	17	52.5	13.8	52	52	51	48.6	15.1	49	49	48	43.4	16.6	43	43	43	
	15	51.1	13.7	51	51	51	47.3	15	47	47	47	42	16.6	42	42	42	
					26	24	22			26	24	22			26	24	22
	23	61.5	14.5	27	21	-	56.3	15.9	25	19	-	49.4	17.8	23	17	-	
	21	57.7	14.2	34	28	22	53.1	15.6	32	26	20	47.2	17.2	29	23	17	
	19	53.9	13.9	41	35	28	49.8	15.2	39	32	26	44.9	16.6	36	30	24	
17	52.5	13.8	44	38	32	48.6	15.1	41	35	29	43.4	16.6	37	31	25		
15	51.1	13.7	48	42	35	47.3	15	44	38	32	42	16.6	39	33	27		
12 240				32	30	28			32	30	28			32	30	28	
	23	66.4	14.7	51	44	37	60.7	15.9	50	43	36	49.6	18.2	46	39	32	
	21	62.3	14.4	59	52	44	57.2	15.5	57	50	43	47.3	17.6	47	46	39	
	19	58.2	14	58	58	52	53.7	15.2	54	54	51	45	17.1	45	45	45	
	17	56.7	14	57	57	56	52.3	15.1	52	52	52	43.6	17.1	44	44	44	
	15	55.2	13.9	55	55	55	51	15	51	51	51	42.1	17.1	42	42	42	
					26	24	22			26	24	22			26	24	22
	23	66.4	14.7	30	23	-	60.7	15.9	29	22	-	49.6	18.2	25	18	-	
	21	62.3	14.4	37	30	23	57.2	15.5	36	29	22	47.3	17.6	32	25	18	
	19	58.2	14	45	38	31	53.7	15.2	43	36	29	45	17.1	39	32	25	
17	56.7	14	49	41	34	52.3	15.1	47	40	32	43.6	17.1	40	33	26		
15	55.2	13.9	52	45	37	51	15	47	40	33	42.1	17.1	39	31	24		

These capacities are gross ratings. For net capacity, correct with the heat of the supply air blower motor. Refer to the appropriate Blower performance Table for the kW of the supply air blower motor.



9 - Capacity Ratings (Cont'd)

9.1.5 - DIG 240

Air On Evaporator Coil		Temperature of air on condensing coil															
		27°C					35°C					46°C					
		Total Cap. kW	Power Input kW	Sensible Capacity kW			Total Cap. kW	Power Input kW	Sensible Capacity kW			Total Cap. kW	Power Input kW	Sensible Capacity kW			
m ³ /h	WB °C	Entering Dry Bulb °C															
		32	30	28	32	30	28	32	30	28	32	30	28	32	30	28	
10 080	23	71.2	18.5	56	50	44	65.4	20.4	52	46	40	59.4	23.1	49	42	36	
	21	68.7	18.3	60	54	48	63.1	20.1	57	51	45	56.6	22.5	54	47	41	
	19	66.3	18.1	65	59	52	60.9	19.8	61	56	50	53.8	22	54	53	46	
	17	64.1	17.9	64	62	56	58.8	19.6	59	58	52	52.8	21.9	53	53	48	
	15	62	17.6	62	62	60	56.7	19.3	57	57	54	51.7	21.9	52	52	49	
					26	24	22			26	24	22			26	24	22
	23	71.2	18.5	37	31	-	65.4	20.4	34	28	-	59.4	23.1	30	24	-	
	21	68.7	18.3	42	36	30	63.1	20.1	39	33	27	56.6	22.5	35	29	23	
	19	66.3	18.1	46	40	34	60.9	19.8	44	38	31	53.8	22	40	34	28	
	17	64.1	17.9	50	44	38	58.8	19.6	46	40	34	52.8	21.9	42	36	30	
	15	62	17.6	54	47	41	56.7	19.3	48	42	36	51.7	21.9	43	37	31	
	13 680				32	30	28			32	30	28			32	30	28
		23	76.9	18.8	68	60	52	71.3	20.7	65	57	49	63.8	23.3	60	52	44
		21	74.3	18.6	73	65	57	68.9	20.5	69	62	54	60.8	22.7	61	58	50
19		71.6	18.4	72	70	62	66.4	20.2	66	66	60	57.8	22.2	58	58	56	
17		69.3	18.2	69	69	67	64.2	19.9	64	64	63	56.7	22.1	57	57	57	
15		67	17.9	67	67	67	61.9	19.7	62	62	62	55.5	22.1	56	56	56	
					26	24	22			26	24	22			26	24	22
23		76.9	18.8	44	36	-	71.3	20.7	41	33	-	63.8	23.3	36	28	-	
21		74.3	18.6	49	41	33	68.9	20.5	46	38	30	60.8	22.7	42	34	26	
19		71.6	18.4	54	46	38	66.4	20.2	52	44	36	57.8	22.2	48	40	32	
17		69.3	18.2	59	51	43	64.2	19.9	55	47	39	56.7	22.1	50	42	34	
15		67	17.9	63	55	47	61.9	19.7	58	50	42	55.5	22.1	52	44	35	
15 840					32	30	28			32	30	28			32	30	28
		23	80.4	19	74	65	55	74.9	21	71	61	52	66.4	23.4	65	56	47
	21	77.6	18.8	78	70	61	72.3	20.7	72	68	58	63.3	22.9	63	62	53	
	19	74.8	18.6	75	75	67	69.8	20.4	70	70	65	60.2	22.3	60	60	60	
	17	72.4	18.4	72	72	71	67.4	20.1	67	67	67	59	22.3	59	59	59	
	15	70	18.1	70	70	70	65	19.9	65	65	65	57.8	22.2	58	58	58	
					26	24	22			26	24	22			26	24	22
	23	80.4	19	46	37	-	74.9	21	43	34	-	66.4	23.4	38	29	-	
	21	77.6	18.8	52	43	33	72.3	20.7	49	40	31	63.3	22.9	44	35	26	
	19	74.8	18.6	57	48	39	69.8	20.4	55	46	37	60.2	22.3	51	41	32	
	17	72.4	18.4	62	53	44	67.4	20.1	58	49	40	59	22.3	53	43	34	
	15	70	18.1	65	56	47	65	19.9	60	51	42	57.8	22.2	53	44	35	

These capacities are gross ratings. For net capacity, correct with the heat of the supply air blower motor.
Refer to the appropriate Blower performance Table for the kW of the supply air blower motor.

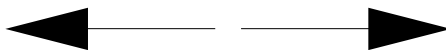

9 - Capacity Ratings (Cont'd)

9.1.6 - DIG 300

Air On Evaporator Coil		Temperature of air on condensing coil																	
		27°C						35°C						46°C					
		Total Cap. kW	Power Input kW	Sensible Capacity kW				Total Cap. kW	Power Input kW	Sensible Capacity kW				Total Cap. kW	Power Input kW	Sensible Capacity kW			
				Entering Dry Bulb °C						Entering Dry Bulb °C						Entering Dry Bulb °C			
m³/h	WB °C																		
		31	28	25	22	31	28	25	22	31	28	25	22						
20 700	23	110.3	27.7	77	55	35	0	103.7	30.5	76	54	34	0	94.4	34.4	74	52	32	0
	20	104.7	27.2	105	80	57	37	99.3	30.0	99	78	46	36	91.5	33.9	92	76	54	33
	17	104.5	27.2	105	99	82	60	99.1	30.0	99	93	80	58	91.4	33.9	91	86	78	55
	14	104.4	27.1	104	98	92	87	98.9	30.0	99	93	87	82	91.3	33.8	91	85	80	74
17 000	23	107.8	27.5	68	51	33	0	101.4	30.3	67	49	32	0	92.4	34.0	66	47	30	0
	20	100.0	26.7	90	71	53	35	94.0	29.4	89	69	51	34	87.2	33.2	87	68	49	31
	17	99.3	26.7	99	94	74	55	94.2	29.4	94	89	82	53	87.0	33.1	87	81	69	50
	14	99.1	26.7	99	94	88	76	94.1	29.3	94	89	83	74	86.8	33.1	87	81	76	71
13 500	23	104.4	27.2	60	45	31	0	98.3	29.9	58	44	30	0	89.6	33.6	57	42	27	0
	20	95.9	26.4	78	62	48	33	90.2	28.9	76	61	46	31	82.1	32.2	74	59	44	29
	17	92.4	26.0	92	80	65	50	87.7	28.5	88	79	63	48	81.0	32.0	81	76	61	45
	14	92.3	26.0	92	87	82	66	87.6	28.5	88	83	78	65	80.9	32.0	81	76	71	62

9.2 - Gas Heat Application Data

Type of burner	Input capacity (nett) kW	Output capacity kW	Gas rate* m³/h	Temperature rise °C at full input**	
				Min.	Max.
N130	42,6	37,8	4,3	17	33
N165	53,5	47,5	5,4	17	33
N200	63,7	56,6	6,4	17	33
N320	85,2	75,8	8,5	17	33

Note: Gas Heaters are shipped for 2nd group (natural) gases, but can be converted to 3rd group (liquified petroleum) gases with a conversion accessory.

* Based on input (Nett) and 2nd -H group, G20 (methane) nett fuel value (9.97 kWh/m³).

** The air flow must be adjusted to obtain a temperature rise within the range shown.

10 - Blower Performance

DIG 090 - Side Flow duct applications

Blower Speed RPM	m³/h														
	3800			4500			5100			5700			6400		
	ESP Pa	Output kW	Input kW	ESP Pa	Output kW	Input kW	ESP Pa	Output kW	Input kW	ESP Pa	Output kW	Input kW	ESP Pa	Output kW	Input kW
950	191	0.8	1.0	138	0.9	1.1	78	1.1	1.2	-	-	-	-	-	-
1005	228	0.9	1.1	176	1.0	1.2	116	1.1	1.3	43	1.3	1.5	-	-	-
1060	271	1.0	1.1	218	1.1	1.3	159	1.2	1.4	86	1.4	1.6	-	-	-
1120	322	1.0	1.2	270	1.2	1.4	210	1.3	1.6	138	1.5	1.8	60	1.7	2.0
1175	375	1.1	1.4	323	1.3	1.5	263	1.4	1.7	190	1.6	1.9	-	-	-
1230	432	1.2	1.5	380	1.4	1.7	320	1.6	1.9	-	-	-	-	-	-

DIG 090 - Down Flow duct applications

Blower Speed RPM	m³/h														
	3800			4500			5100			5700			6400		
	ESP Pa	Output kW	Input kW	ESP Pa	Output kW	Input kW	ESP Pa	Output kW	Input kW	ESP Pa	Output kW	Input kW	ESP Pa	Output kW	Input kW
950	173	0.8	1.0	116	0.9	1.1	46	1.1	1.2	-	-	-	-	-	-
1005	211	0.9	1.1	154	1.0	1.2	84	1.1	1.3	-	-	-	-	-	-
1060	253	1.0	1.2	248	1.2	1.4	178	1.3	1.6	95	1.5	1.8	-	-	-
1120	305	1.0	1.2	248	1.2	1.4	178	1.3	1.6	95	1.5	1.8	-	-	-
1175	357	1.1	1.4	300	1.3	1.5	230	1.4	1.7	148	1.6	1.9	-	-	-
1230	415	1.2	1.5	358	1.4	1.7	288	1.6	1.9	-	-	-	-	-	-

PSD = Pression statique disponible — P.Util = Puissance utile fournie — P.Abs = Puissance absorbée

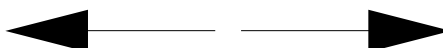

10 - Blower Performance (Cont'd)

DIG 120

Side Flow duct applications

Blower Speed RPM	m ³ /h														
	5100			5900			6800			7600			8500		
	ESP Pa	Output kW	Input kW	ESP Pa	Output kW	Input kW	ESP Pa	Output kW	Input kW	ESP Pa	Output kW	Input kW	ESP Pa	Output kW	Input kW
880	283	1.1	1.3	231	1.2	1.5	176	1.4	1.7	102	1.6	2.0	20	1.8	2.2
930	332	1.2	1.5	282	1.4	1.7	228	1.5	1.9	156	1.7	2.1	76	1.9	2.4
975	377	1.3	1.6	329	1.5	1.8	276	1.7	2.1	206	1.9	2.3	127	2.1	2.6
1025	429	1.4	1.8	381	1.6	2.0	330	1.8	2.2	261	2.0	2.5	184	2.3	2.8
1070	475	1.5	1.9	429	1.7	2.1	380	2.0	2.4	312	2.2	2.7	236	2.4	3.0
1120	528	1.7	2.0	484	1.9	2.3	436	2.1	2.6	370	2.4	2.9	-	-	-

ESP = External static pressure

DIG 120

Down Flow duct applications

Blower Speed RPM	m ³ /h														
	5100			5900			6800			7600			8500		
	ESP Pa	Output kW	Input kW	ESP Pa	Output kW	Input kW	ESP Pa	Output kW	Input kW	ESP Pa	Output kW	Input kW	ESP Pa	Output kW	Input kW
880	250	1.1	1.3	186	1.2	1.5	118	1.4	1.7	27	1.6	2.0	-	-	-
930	300		1.2	1.5	237	1.4	1.7	171	1.5	1.9	82	1.7	2.1	-	--
975	345	1.3	1.6	284	1.5	1.8	219	1.7	2.1	131	1.9	2.3	37	2.1	2.6
1025	396	1.4	1.8	336	1.6	2.0	273	1.8	2.2	187	2.0	2.5	94	2.3	2.8
1070	443	1.5	1.9	385	1.7	2.1	323	2.0	2.4	238	2.2	2.7	147	2.4	3.0
1120	496	1.7	2.0	439	1.9	2.3	379	2.1	2.6	295	2.4	2.9	-	-	-

ESP = External static pressure

DIG 150

Side Flow duct applications

Blower Speed RPM	m ³ /h														
	6500			7600			8600			9700			10800		
	ESP Pa	Output kW	Input kW	ESP Pa	Output kW	Input kW	ESP Pa	Output kW	Input kW	ESP Pa	Output kW	Input kW	ESP Pa	Output kW	Input kW
960	270	1.5	1.8	179	1.7	2.1	912.1	91	2.1	2.5	22	2.6	3.1	-	--
1000	321	1.6	2.0	229	1.9	2.3	140	2.3	2.7	70	2.8	3.3	-	-	-
1040	372	1.8	2.2	280	2.1	2.5	190	2.5	3.0	119	3.0	3.6	44	3.7	4.4
1080	424	2.0	2.4	331	2.3	2.8	240	2.7	3.3	169	3.3	3.9	93	3.9	4.7
1120	476	2.3	2.7	382	2.5	3.0	291	3.0	3.6	219	3.5	4.2	142	4.2	5.0
1160	529	2.5	3.0	434	2.8	3.3	343	3.2	3.9	269	3.8	4.5	-	-	-

ESP = External static pressure

DIG 150

Down Flow duct applications

Blower Speed RPM	m ³ /h														
	6500			7600			8600			9700			10800		
	ESP Pa	Output kW	Input kW	ESP Pa	Output kW	Input kW	ESP Pa	Output kW	Input kW	ESP Pa	Output kW	Input kW	ESP Pa	Output kW	Input kW
960	213	1.5	1.8	104	1.7	2.1	-	-	-	-	-	-	-	-	-
1000	264	1.6	2.0	154	1.9	2.3	51	2.3	2.7	-	-	-	-	-	-
1040	315	1.8	2.2	205	2.1	2.5	100	2.5	3.0	30	3.0	3.6	-	-	-
1080	367	2.0	2.4	256	2.3	2.8	151	2.7	3.3	79	3.3	3.9	-	-	-
1120	419	2.3	2.7	307	2.5	3.0	201	3.0	3.6	129	3.5	4.2	42	4.2	5.0
1160	472	2.5	3.0	360	2.8	3.3	253	3.2	3.9	179	3.8	4.5	-	-	-

ESP = External static pressure



10 - Blower Performance (Cont'd)

DIG 180 - STANDARD DRIVE. Down Flow duct applications

Blower Speed RPM	Motor Pulley (turns open)	m ³ /h														
		7800			8800			10100			11200			12200		
		ESP Pa	Output kW	Input kW	ESP Pa	Output kW	Input kW	ESP Pa	Output kW	Input kW	ESP Pa	Output kW	Input kW	ESP Pa	Output kW	Input kW
845	6.0	206	1.8	2.2	146	2.0	2.5	80	2.4	2.8	18	2.7	3.2	-	-	-
885	5.0	242	1.9	2.3	183	2.2	2.6	117	2.5	3.0	56	2.9	3.4	-	-	-
925	4.0	278	2.0	2.4	220	2.3	2.7	155	2.7	3.2	94	3.1	3.7	28	3.5	4.2
960	3.0	311	2.1	2.5	253	2.4	2.9	189	2.8	3.4	128	3.2	3.9	63	3.7	4.5
1000	2.0	349	2.2	2.6	292	2.6	3.1	228	3.0	3.6	168	3.5	4.2	103	4.0	4.8
1040	1.0	387	2.3	2.8	331	2.7	3.3	268	3.2	3.9	209	3.7	4.4	144	4.3	5.1

DIG 180 - HIGH SPEED DRIVE. Down Flow duct applications

Blower Speed RPM	Motor Pulley (turns open)	m ³ /h														
		7800			8800			10100			11200			12200		
		ESP Pa	Output kW	Input kW	ESP Pa	Output kW	Input kW	ESP Pa	Output kW	Input kW	ESP Pa	Output kW	Input kW	ESP Pa	Output kW	Input kW
1030	6.0	378	2.3	2.7	321	2.7	3.2	258	3.2	3.8	199	3.6	4.4	134	4.2	5.0
1070	5.0	417	2.4	2.9	361	2.9	3.4	299	3.4	4.1	240	3.9	4.7	-	-	-
1115	4.0	461	2.6	3.1	407	3.1	3.7	345	3.7	4.4	286	4.2	5.0	-	-	-
1155	3.0	502	2.8	3.3	448	3.3	4.0	387	3.9	4.7	-	-	-	-	-	-
1200	2.0	548	3.0	3.6	495	3.6	4.3	435	4.2	5.0	-	-	-	-	-	-
1240	1.0	590	3.2	3.8	538	3.8	4.6	-	-	-	-	-	-	-	-	-

DIG 240 - STANDARD DRIVE. Down Flow duct applications

Blower Speed RPM	Motor Pulley (turns open)	m ³ /h														
		10100			11900			13700			14800			15800		
		ESP Pa	Output kW	Input kW	ESP Pa	Output kW	Input kW	ESP Pa	Output kW	Input kW	ESP Pa	Output kW	Input kW	ESP Pa	Output kW	Input kW
765	6.0	202	2.1	2.4	80	2.7	3.1	-	-	-	-	-	-	-	-	-
795	5.0	238	2.3	2.6	117	2.9	3.3	-	-	-	-	-	-	-	-	-
820	4.0	268	2.4	2.7	150	3.0	3.4	-	-	-	-	-	-	-	-	-
850	3.0	305	2.5	2.9	189	3.2	3.7	50	3.9	4.5	-	-	-	-	-	-
875	2.0	336	2.7	3.0	222	3.4	3.8	85	4.1	4.7	-	-	-	-	-	-
905	1.0	347	2.8	3.2	262	3.6	4.1	128	4.3	5.0	37	4.8	5.5	-	-	-

DIG 240 - HIGH SPEED DRIVE. Down Flow duct applications

Blower Speed RPM	Motor Pulley (turns open)	m ³ /h														
		10100			11900			13700			14800			15800		
		ESP Pa	Output kW	Input kW	ESP Pa	Output kW	Input kW	ESP Pa	Output kW	Input kW	ESP Pa	Output kW	Input kW	ESP Pa	Output kW	Input kW
895	6.0	361	2.8	3.2	249	3.5	4.0	114	4.3	4.9	22	4.7	5.4	-	-	-
925	5.0	400	2.9	3.4	290	3.7	4.2	157	4.5	5.1	66	5.0	5.7	-	-	-
955	4.0	439	3.1	3.6	332	3.9	4.4	201	4.7	5.4	112	5.2	6.0	15	5.8	6.6
990	3.0	486	3.3	3.8	381	4.1	4.7	254	5.0	5.7	166	5.5	6.3	70	6.1	7.0
1020	2.0	527	3.5	4.0	425	4.3	5.0	299	5.2	6.0	213	5.8	6.7	119	6.4	7.3
1050	1.0	569	3.7	4.2	469	4.6	5.2	346	5.5	6.3	261	6.1	7.0	-	-	-
1080	0.0	612	3.9	4.4	514	4.8	5.5	393	5.8	6.6	310	6.4	7.3	-	-	-

DIG 300 - Bottom duct applications - Standard drive

Blower Speed RPM	Motor Pulley	m ³ /h														
		13 600			15 300			17 000			18 700			20 400		
		ESP (Pa)	Output (kW)	Input (kW)	ESP (Pa)	Output (kW)	Input (kW)	ESP (Pa)	Output (kW)	Input (kW)	ESP (Pa)	Output (kW)	Input (kW)	ESP (Pa)	Output (kW)	Input (kW)
1 010	6.0**	374	5.7	6.4	224	6.6	7.5	100	7.6	8.7	-	-	-	-	-	-
1 064	5.0	448	6.1	6.9	324	7.2	8.0	219	8.3	9.3	50	9.5	10.6	-	-	-
1 118	4.0	548	6.6	7.4	423	7.7	8.6	319	8.9	10.0	224	10.1	11.4	25	11.5	12.9
1 172	3.0	648	7.0	7.9	523	8.2	9.2	419	9.5	10.6	249	10.8	12.2	100	12.2	13.7

ESP = External static pressure



10 - Blower Performance (Cont'd)

DIG 300 - HIGH SPEED DRIVE. Down Flow duct applications

Blower Speed RPM	Motor Pulley (turns open)	m ³ /h														
		10100			11900			13700			14800			15800		
		ESP Pa	Output kW	Input kW	ESP Pa	Output kW	Input kW	ESP Pa	Output kW	Input kW	ESP Pa	Output kW	Input kW	ESP Pa	Output kW	Input kW
1 080	6	483	6	6.9	356	8.2	8	229	8.2	9.3	76	9.3	10.6	-	-	-
1 130	5	686	6.9	7.9	559	8.1	9.2	432	9.3	10.6	279	10.7	12.2	127	12.1	13.7
1 118	4	737	7.1	8.1	610	8.4	9.6	483	9.7	11.1	330	11	12.6	178	12.3	14.2
1 236	3	787	7.4	8.4	660	8.7	9.9	533	10	11.4	381	11.4	13	-	-	-
1 270	2.5	-	-	-	762	9.3	10.6	635	10.7	12.2	508	12.2	13.9	-	-	-

11 - Indoor Coil Pressure Drops

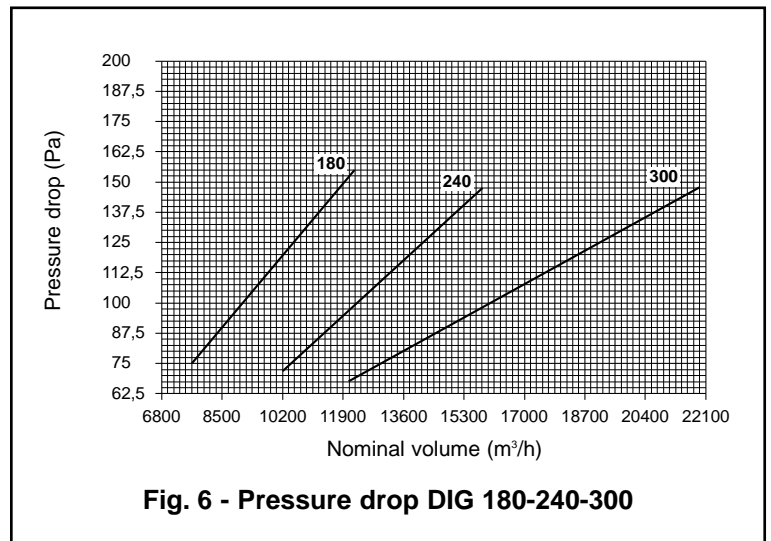
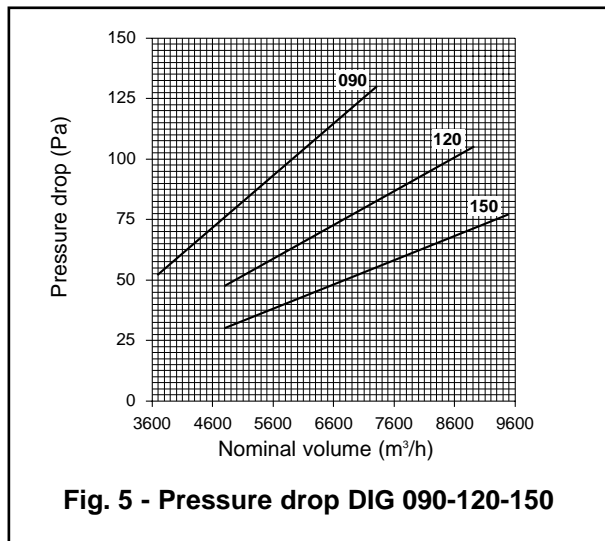

12 - Accessory Static Resistances

DIG 090-120-150

Description	External static pressure drop (Pa)				
	m ³ /h				
	3 400	5 100	6 800	8 500	10 200
Economizer	5.0	5.0	7.5	12.5	17.4

DIG 300

Accessory	External static pressure drop (Pa)		
	m ³ /h		
	11 330	14 150	16 990
Wet coil	25	25	25
Economizer (option)	25	25	25
Sideflow applications**	50	75	125

DIG 180-240-300

Description	External static pressure drop (Pa)									
	m ³ /h									
	DIG 180					DIG 240				
	7 800	8 800	10 100	11 200	12 200	10 100	11 900	13 700	14 800	15 800
Wet indoor coil *	25	25	25	25	25	25	25	25	25	25
Economizer**	6	8	10	12	15	10	14	18	21	24
Sideflow Applications	150	126	106	92	81	106	84	70	66	64
	Supply duct**	12	12	12	12	12	12	12	12	12
	Return duct**	12	12	12	12	12	12	12	12	12

* Deduct these resistance values from the available external static pressures shown in the respective Blower Performance Table.

** Since the resistance to air flow will be less for sideflow duct connections than for downflow duct connections, add these pressures to the ESP values listed in the respective blower performance table.

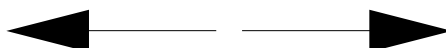

13 - Dimensions

DIG 090-120-150

All dimensions are in mm. They are subject to change without notice. Certified dimensions will be provided upon request.

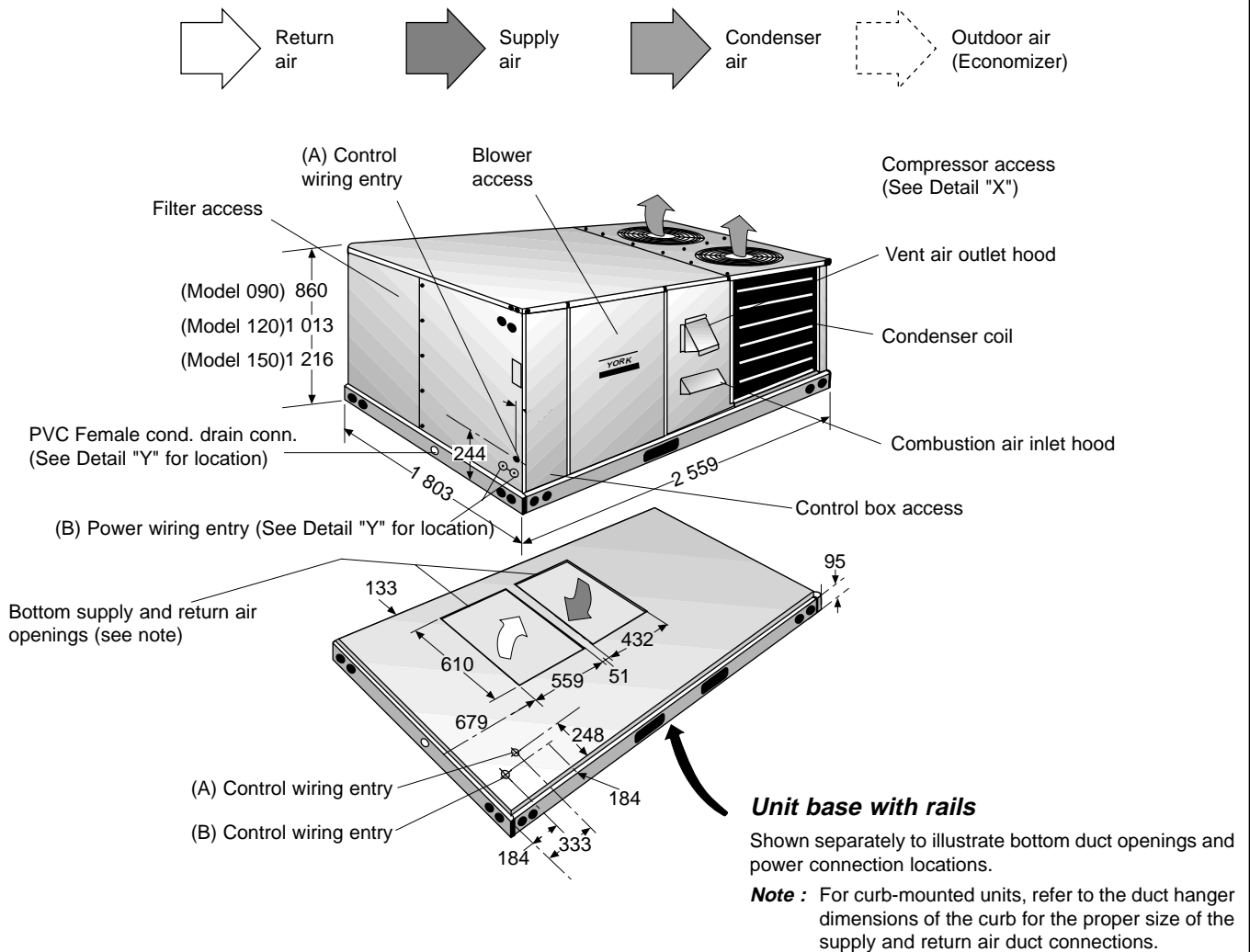

Fig. 7 - Front view

Utilities entry data

Hole	Opening size (dia.)	Used for	
A	19 mm	Control wiring	Side
	22 mm		Bottom*
B	51 mm	Power wiring (side or bottom)*	

* Openings in the bottom of the unit can be located by the slice in the insulation.

Clearances (mm)

Front	610
Back	300 (less economiser)
	915 (with economiser)
Left side (Filter access)	610 (less economiser)
	1 370 (with economiser)
Right side (Cond. coil)	610
Below unit	0
Above unit*	1 525 with 915 maximum horizontal overhang (for condenser air discharge)

* Units must be installed outdoors. Overhanging structures or shrubs should not obstruct condenser air discharge outlet.

13 - Dimensions (Cont'd)

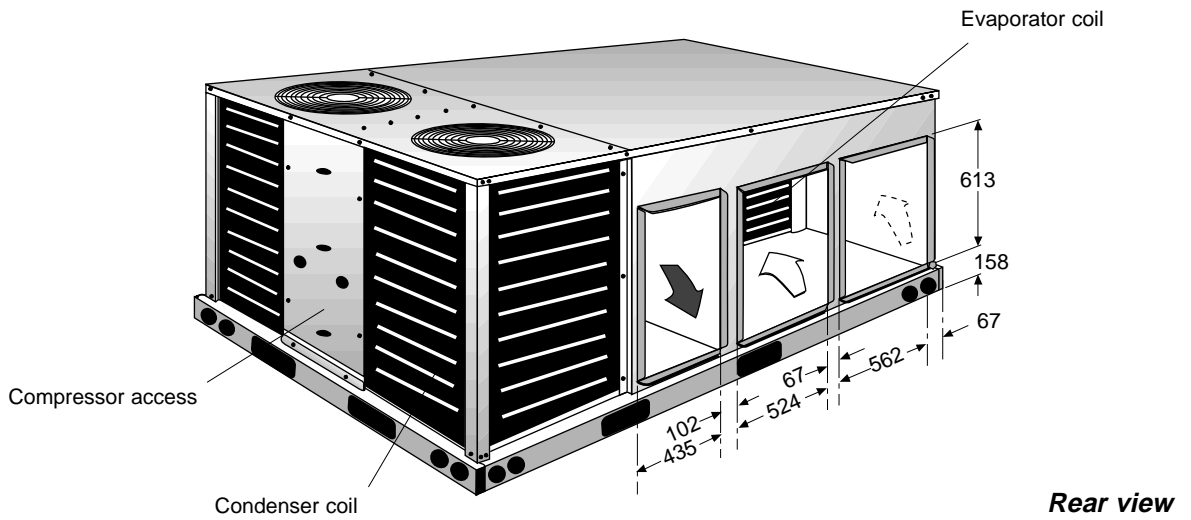

Fig. 8 - Detail "X" - Side supply and return air duct openings - DIG 090-120-150

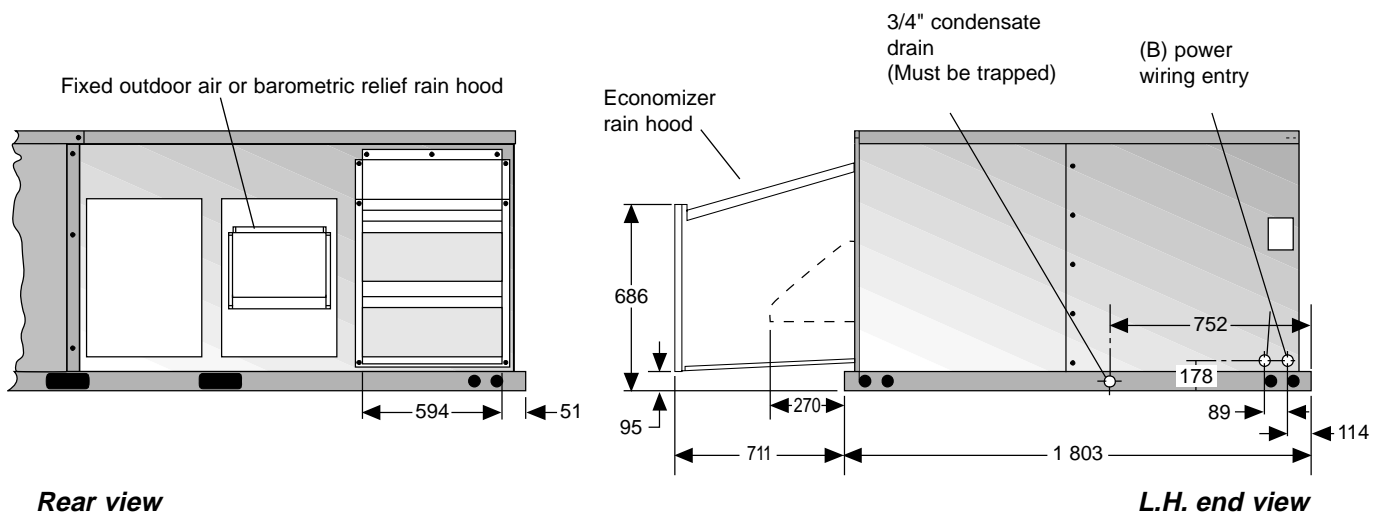

Fig. 9 - Detail "Y" - Unit with economizer and fixed outdoor air hoods - DIG 090-120-150



13 - Dimensions (Cont'd)

DIG 180-240-300

All dimensions are in mm. They are subject to change without notice. Certified dimensions will be provided upon request.

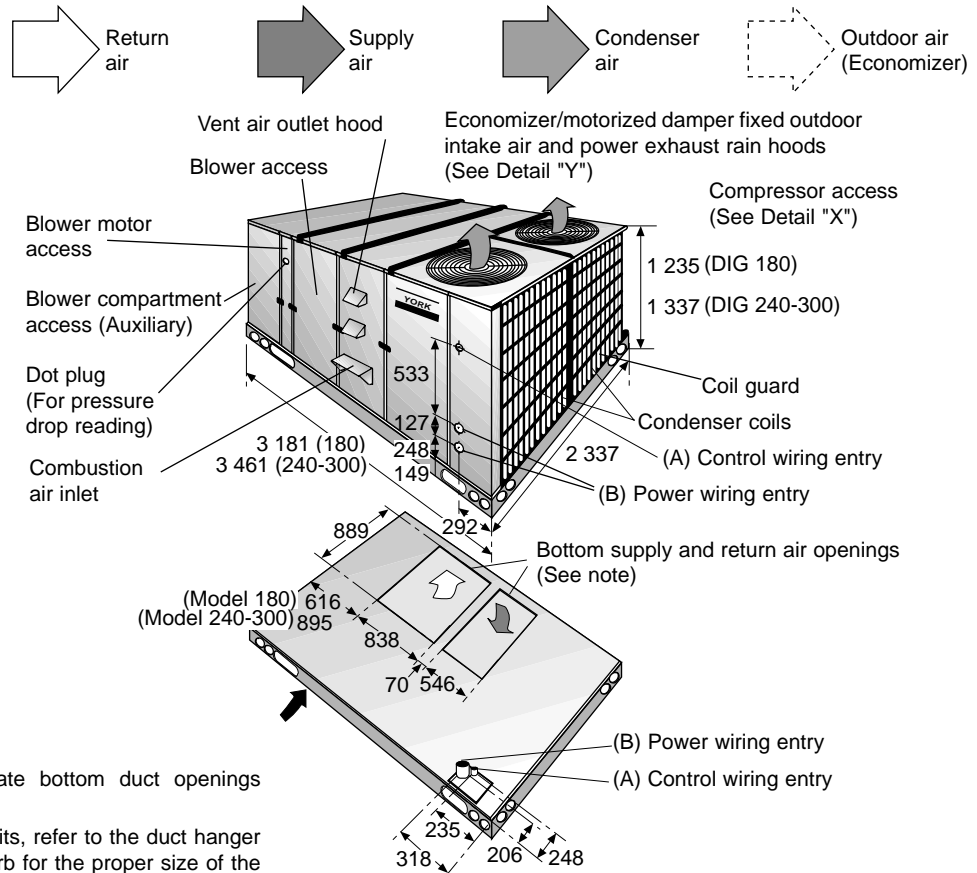

Unit base with rails

Shown separately to illustrate bottom duct openings power connection locations.

Note : For curb mounted units, refer to the duct hanger dimensions of the curb for the proper size of the supply and return air duct connections.

Fig. 10 - Front view - DIG 180-240-300

Utilities entry data

Hole	Opening size (dia.)	Used for	
A	29 mm	Control wiring	Front
	19 NPS (Fem.)		Bottom*
B	92 mm	Power wiring	Front
	76 NPS (Fem.)		Bottom*

Clearances (mm)

Front	915
Back	610 (less economiser)
	1245 (with economiser)
Left side (Filter access)	610
Right side (Cond. coil)	915
Below unit	0
Above unit*	1830 with 915 maximum horizontal overhang (for condenser air discharge)

* Units must be installed outdoors. Overhanging structures or shrubs should not obstruct condenser air discharge outlet.

13 - Dimensions (Cont'd)

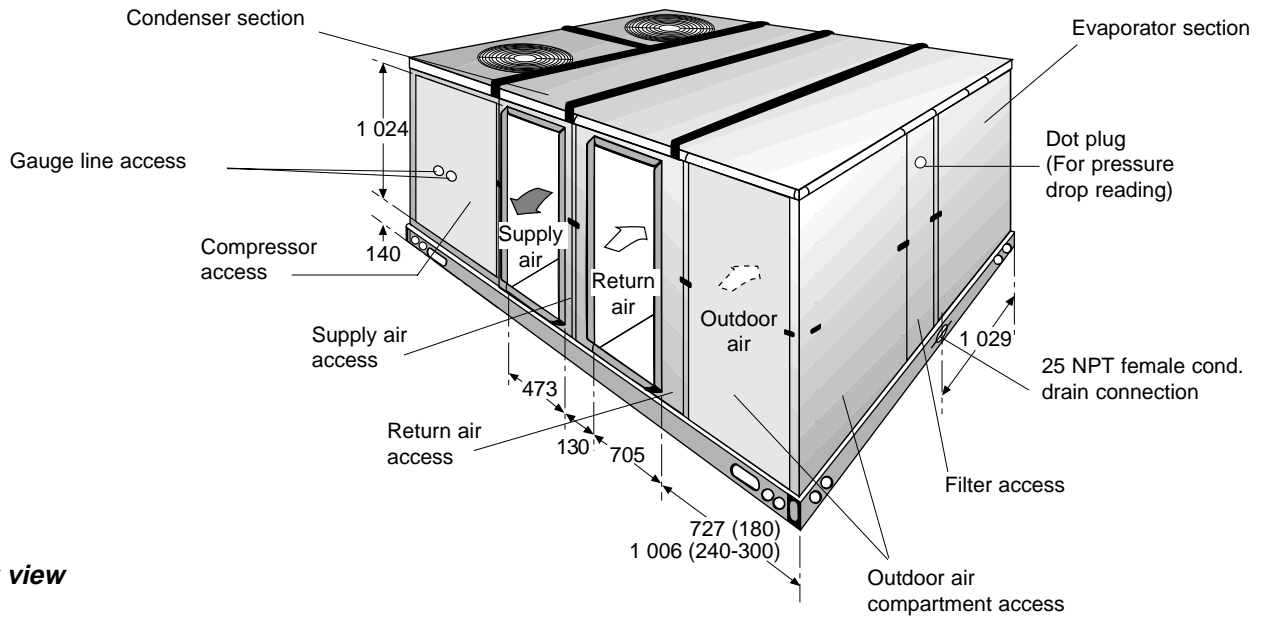

Rear view

Fig. 11 - Detail "X"

Accessory side supply and return air openings - DIG 180-240-300

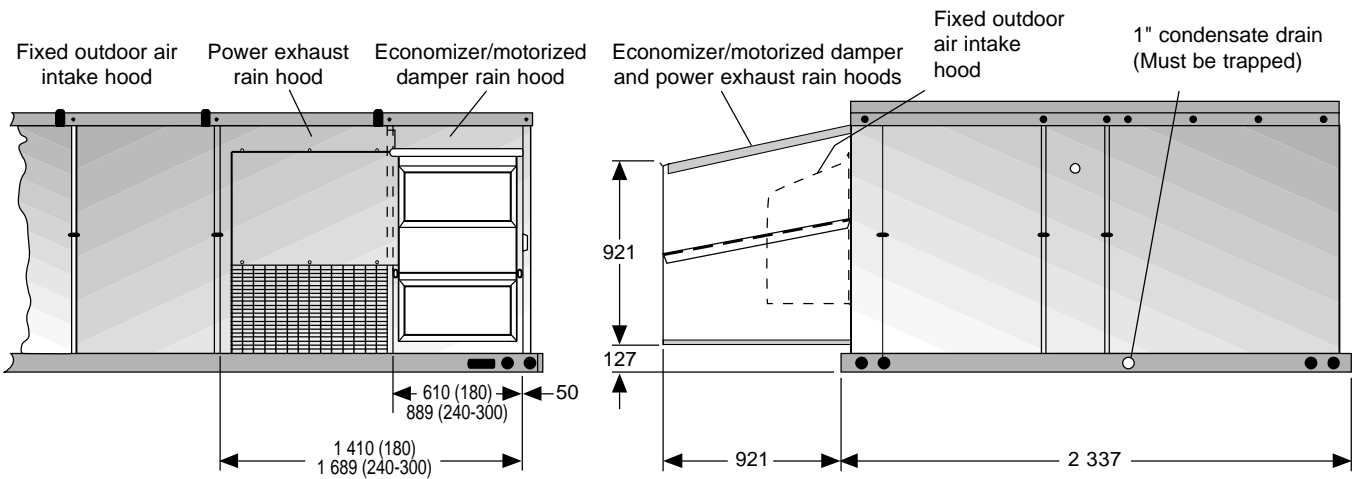

Rear view

L.H. end view

Fig. 12 - Detail "Y" - Unit with rain hoods - DIG 180-240-300



14 - Roof Curb

14.1 - Roof Curb Dimensions

DIG 090-120-150

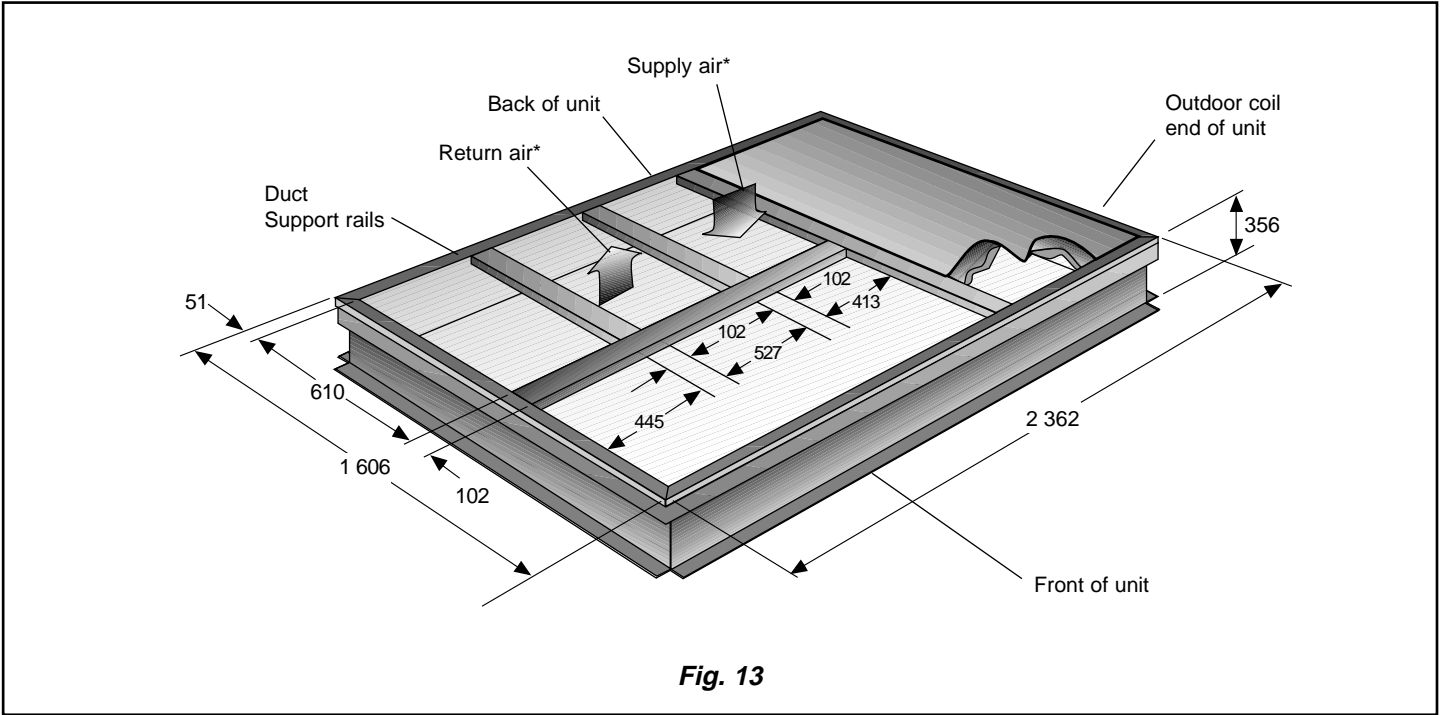

* Supply and Return Air (including duct support rails) as shown, are typical for **bottom** duct applications. For location of **horizontal** duct applications (on back of unit), refer to Unit Dimension details.

DIG 180-240-300

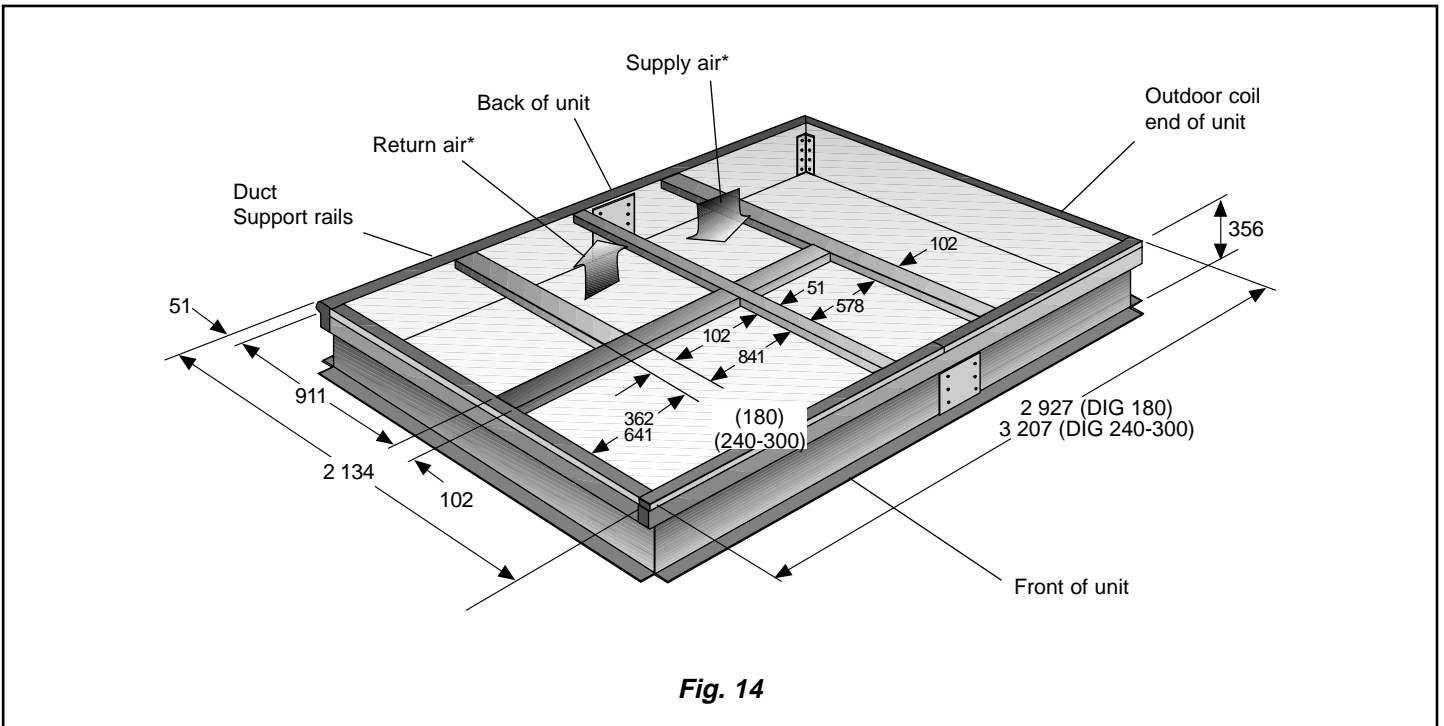

* Supply and Return Air (including duct support rails) as shown, are typical for **downflow** duct applications. For location of **sideflow** duct applications (on back of unit), refer to Unit Dimension details.

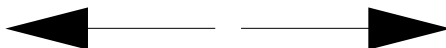

14 - Roof Curb (Cont'd)

14.2 - Unit and Curb Application

DIG 090-120-150-180-240-300

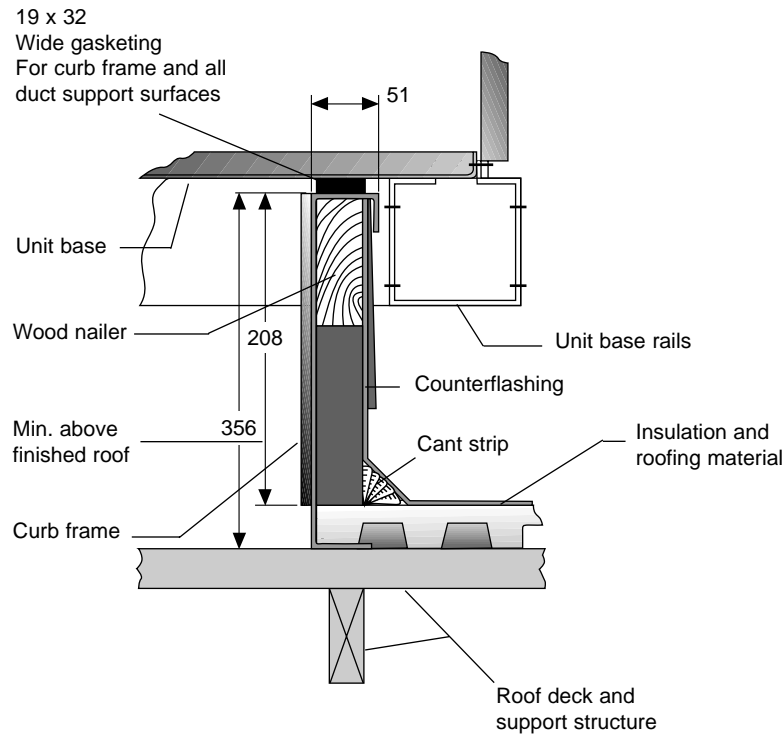

Fig. 15

15 - Safety

CAUTION

This product must be installed in strict compliance with the enclosed installation instructions and any applicable local, state, and national codes including, but not limited to, building, electrical, and mechanical codes.

WARNING

Incorrect installation may create a condition where the operation of the product could cause personal injury or property damage. Prior to install and start up the unit read the safety labels and the installation instructions.

FOR YOUR SAFETY

PRIOR ANY INTERVENTION, SWITCH OFF THE POWER SUPPLY

If you smell gas :

1. Don't touch electrical switches.
2. Extinguish any open flame.
3. Immediately call your gas supplier.



16 - Inspection

As soon as a unit is received, it should be inspected for possible damage during transit. If damage is evident, the extent of the damage should be noted on the carrier's freight bill.

A separate request for inspection by the carrier's agent should be made in writing.

See Local Distributor for additional information.

17 - Positioning

17.1 - Location

Use the following guidelines to select a suitable location for these units.

1. Unit is designed for outdoor installation only.
2. Outdoor coils must have an unlimited supply of air.
3. For ground level installation, use a level concrete slab with a minimum thickness of 102 mm. The length and width should be at least 152 mm greater than the unit base rails. Do not tie slab to the building foundation.
4. Roof structure must be able to support the weight of the unit and its options and/or accessories. Unit must be installed on a solid level roof curb or appropriate angle iron frame.

Caution : If a unit is to be installed on a roof curb or special frame other than a York roof curb, gasketing must be applied to all surfaces that come in contact with the unit underside.

5. Maintain level tolerance to 13 mm (1/2") maximum across the entire length or width of the unit.

17.2 - Rigging and Handling

Exercise care when moving the unit. Do not remove any packaging until the unit is near the place of installation.

Rig the unit by attaching chain or cable slings to the lifting holes provided in the base rails.

Spreaders, whose length exceeds the largest dimension across the unit, **MUST** be used across the top of the unit. Refer to Figure 16.

Units may also be moved or lifted with a forklift, from the front or rear only, providing that an accessory skid is used.

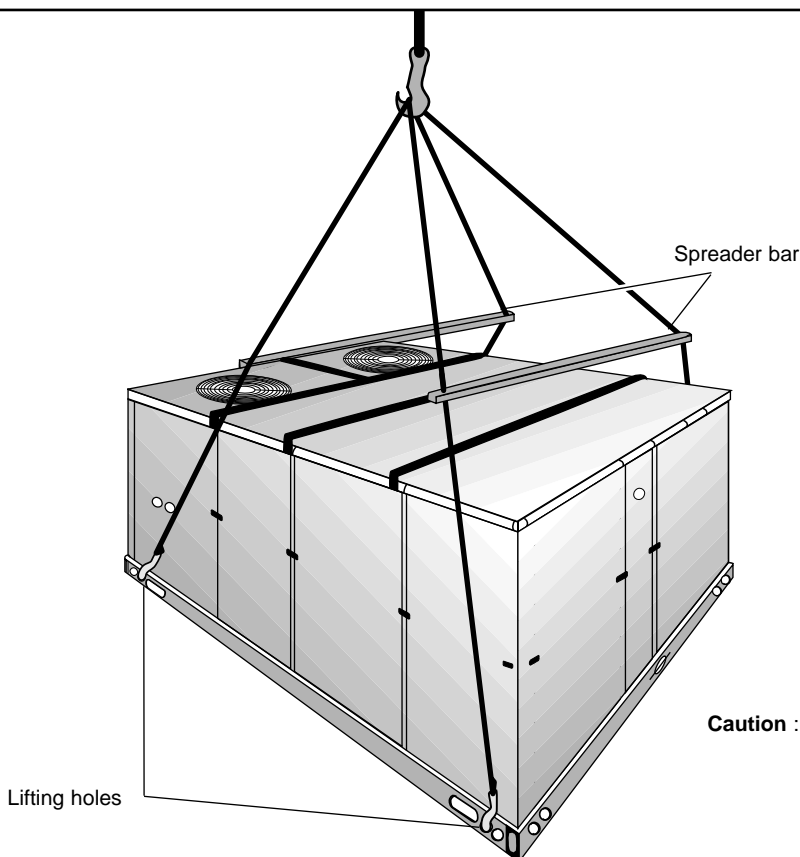

Caution : Before lifting unit, make sure that its weight is distributed equally on the cables so that it will lift evenly.

Fig. 6 - Typical rigging

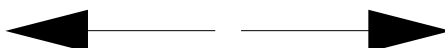

18 - Lifting and Handling

Units may also be moved or lifted with a forklift. Slotted openings in the base rails are provided for this purpose.

Minimum length of forks (m)			
090		120	
1.4			
150	180	240	300
1.4	2.3		

Dimensions	090/120	150	180	240-300
A	2 560	2 560	3 181	3 461
B	1 805	1 805	2 337	
C	1 200	1 150	1 524	
D	830	830	1 143	

18.1 - Center of gravity

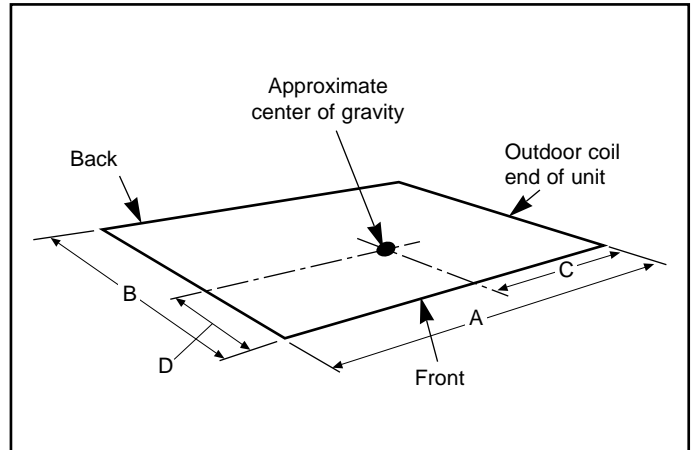

19 - Installation

19.1 - Ductwork

A closed return duct system shall be used. This does not preclude use of economizers or outdoor fresh air intake. The supply and return air duct connections at the unit should be made with flexible joints to minimize noise.

The supply and return air duct systems should be designed for the airflow and static requirements of the job. They should not be sized to match the dimensions of the duct connections on the unit.

Caution : When fastening ductwork to side duct flanges on unit, insert screws through duct flanges only.

Do not insert screws through casing.

Outdoor ductwork must be insulated and waterproofed.

19.1.1 - DIG 090-120-150

Duct covers. Units are shipped with all air duct openings covered.

For **Side** duct applications :

- 1 - Remove and discard the supply and return air duct covers.
- 2 - Connect ductwork to duct flanges on the rear of the units.

For **bottom** duct application :

- 1 - Remove the side supply and return air duct covers to gain access to the bottom supply and return air duct covers.
- 2 - Remove and discard the bottom duct covers.
- 3 - Replace the side duct covers.

19.1.2 - DIG 180-240-300

Duct covers - Units are shipped with the bottom duct openings covered. An accessory flange kit is available for connecting side ducts.

For **bottom** duct applications :

- 1 - Remove the side panel from the supply and return air compartments to gain access to the bottom supply and return air duct covers.
- 2 - Remove and discard the bottom duct covers. (Duct openings are closed with sheet metal covers except when the unit includes a power exhaust option. The covering consists of a heavy black paper composition).
- 3 - Replace the side supply and return air compartment panels.

For **side** duct application :

- 1 - Replace the side panels on the supply and return air compartments with the accessory flange kit panels.
- 2 - Connect ductwork to the duct flanges on the rear of the unit.

19.2 - Condensate drain (Fig. 18-19)

Plumbing must conform to local codes. Use a sealing compound on male pipe threads. Install a condensate drain line from the PVC female connection on the unit to spill into an open drain.

Note : The condensate drain must be trapped to provide proper drainage.

An alternate drain connection (DIG 180/240/300 only) is provided inboard on the same centerline as the exterior location.

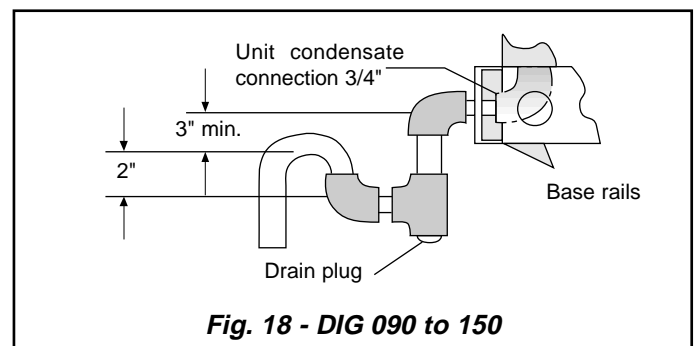

Fig. 18 - DIG 090 to 150

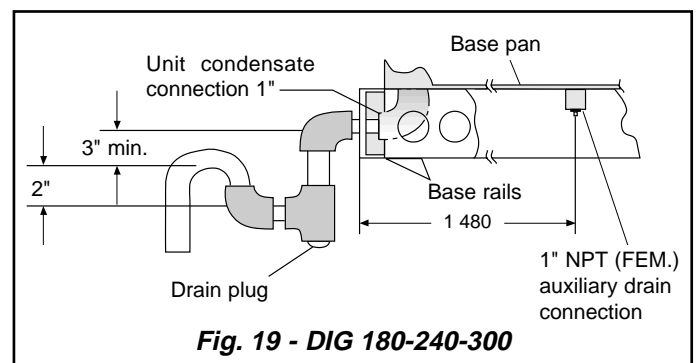

Fig. 19 - DIG 180-240-300

19 - Installation (Cont'd)

19.3 - Filters

Filters are supplied with each unit. Replacement filters may be used with no modification to the filter racks. Filters must always be installed ahead of the indoor coil and must be kept clean or replaced with same size and type.

Dirty filters will reduce the capacity of the unit and will result in frosted coils or safety shutdown.

Filter dimensions	DIG 090
	Qty per unit
305 x 610 x 50	2
405 x 610 x 50	2

Filter dimensions	DIG 120	DIG 150
	Qty per unit	
405 x 610 x 50	2	3
460 x 610 x 50	2	2

Filter dimensions	DIG 180	DIG 240
	Qty per unit	
405 x 510 x 50	-	4
405 x 635 x 50	-	4
460 x 610 x 50	5	-

Filter dimensions	DIG 300
	Qty per unit
355 x 510 x 50	3
405 x 510 x 50	2
405 x 635 x 50	4

19.4 - Barometric relief/fixed outdoor air intake damper assembly

This device is available as standard on model sizes 090-120.

The following description covers the fitting of this device to sizes 090-120.

This damper assembly is shipped inside of the return air compartment. It serves as a barometric relief damper on units with economiser or as a fixed outdoor air intake damper on units less economiser.

On units **with bottom return**, install the damp assembly over the opening in the side return air duct cover. Remove the adhesive backed label covering this opening before installing the damper assembly.

On units **with side return**, install the damper assembly in the return air ductwork as close to the unit as possible. Cut an opening 292 mm high by 444 mm wide in the ductwork to accommodate the damper device.

Attach the damper assembly into position by drilling six (6) holes, 3.5 dia., using the holes in the hood flanges as a template and secure with the screws provided.

On units less economiser, adjust the damper to the desired air flow opening by moving the damper bracket (inside of the hood) to one of the 3 positions provided.

Position 1 will allow approximately 25% recirculated air flow, **position 2** approximately 15% and **position 3** approximately 10%. A screw on each side of the hood secures the bracket in place.

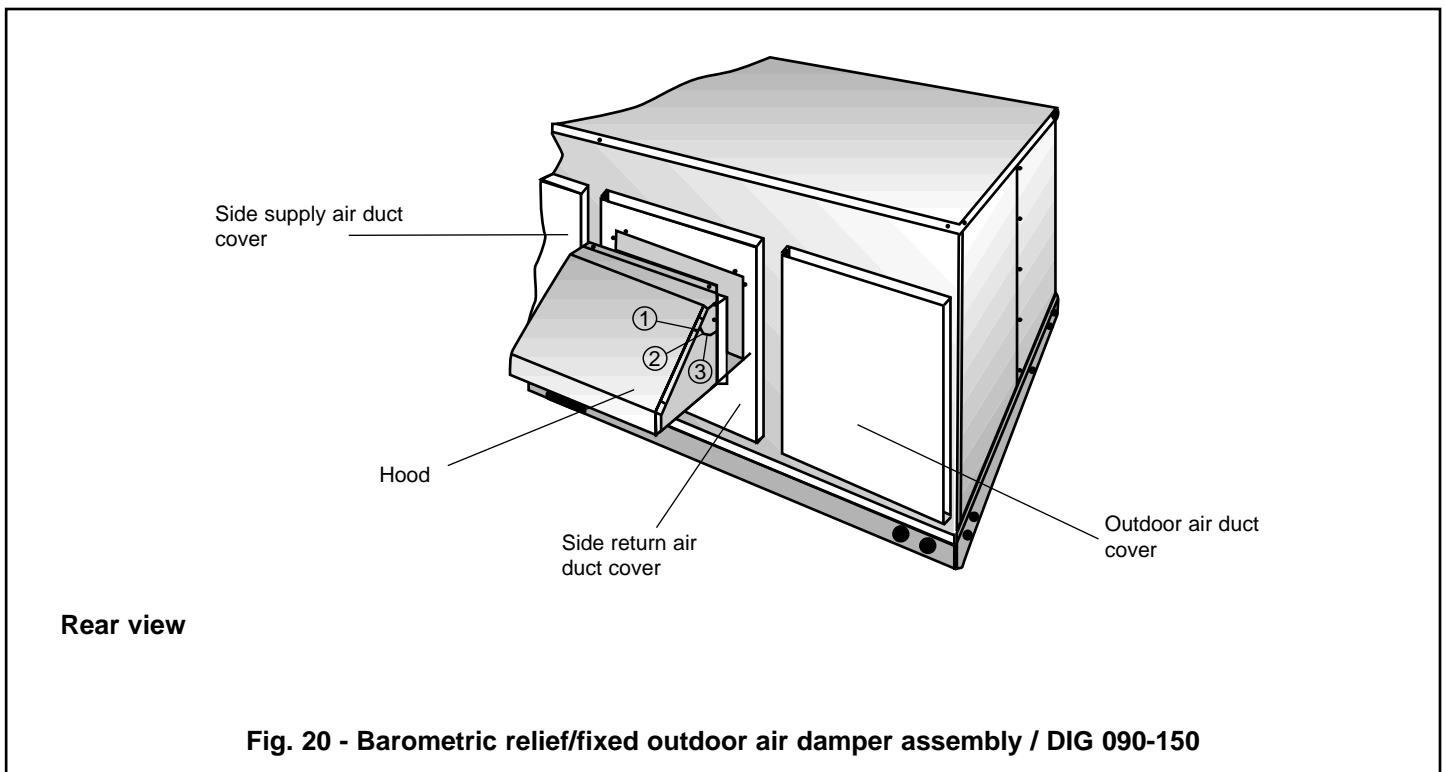

19 - Installation (Cont'd)

19.5 - Fixed outdoor air intake damper

The damper assembly is shipped inside the return air compartment. It is completely assembled and ready for installation. A damper baffle inside the hood is adjustable to provide variable amounts of outdoor air intake on units that are not provided with an economizer or motorized damper option. Refer to figure 9.

Gasketing and mounting screws are provided in a parts bag attached to the hood assembly. Apply gasketing to the three flange surfaces on the hood prior to installing the hood.

Extend gasketing approximately 6 mm beyond the top and bottom of the two side flanges to ensure adequate sealing.

Adjusting the damper to the desired air flow may be done before mounting the hood into position or (after installation) by removing the front hood panel or the screen on the bottom of the hood.

Damper baffle in **position 1** will allow approximately 10% recirculated air flow, **position 2** approximately 15% and, to allow approximately 25%, remove the damper baffle.

On units with **bottom** return air applications, install the damper assembly over the opening in the side return air access panel. Remove and discard the opening cover and the covering over the hood mounting holes (used for shipping) before installing. Secure with the screws provided.

On units with **side** air applications, install the damper assembly on the return air ductwork as close to the unit as possible. Cut an opening 406 mm high by 457 mm wide in the ductwork to accommodate the damper. Using the holes in the hood flanges as a template, drill 3.6 mm dia. (#26 drill) holes into the ductwork and secure with the screws provided.

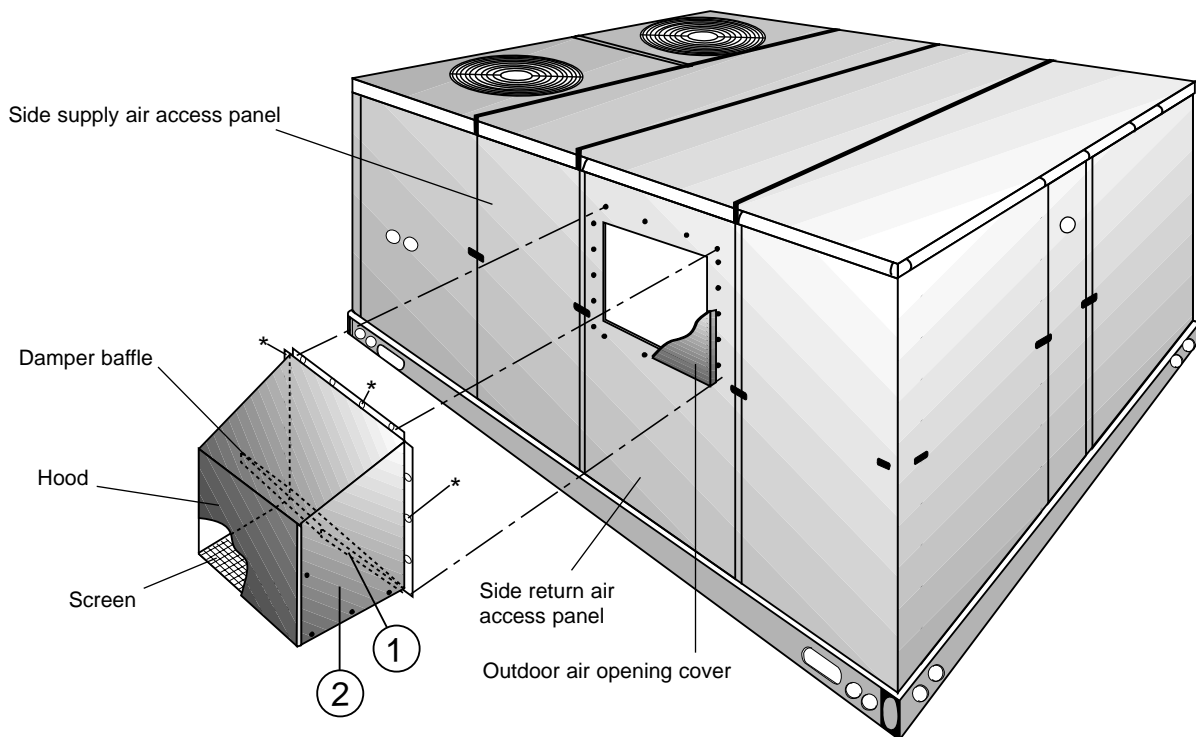

* Gasketed flange

Fig. 21 - Rear view

19 - Installation (Cont'd)

19.6 - Optional economiser rain hood (models 090-150)

The following procedure should be used when assembling an economiser rain hood on to a unit. The outdoor and return air dampers, the damper actuator, the damper linkage, the outdoor and return air divider baffles and all the control sensors are factory mounted as part of the economiser option.

All of the hood components, including the filters, the gasketing and the hardware for assembling are packaged and located within the unit filter section (see figure 22).

1 - With filter section access panel removed, take out the hood components, filters, gasketing and hardware described above. Remove and discard the outdoor air opening cover on back of the unit.

2 - Assemble the rain hood per the following procedures :

a) Apply gasketing to all hood components as follows :

- To the top outside surface and to the flange (toward unit) of each side plate. Extend gasketing 1/4" beyond the top and bottom of the flange to insure adequate sealing.
- To the edge and flanges (in one continuous length) on each side of the centre filter support.
- To the top flange of the bottom filter support (on the side facing the unit).
- To the hood cover flange (only on unit sizes 120 and 150).

b) Attach two filter guide angles to the inside of each side plate using 3 screws for each angle. Note the hole locations on the angles for proper positioning when attaching them on the side plates. Tighten screws.

c) Attach the two side plates to the centre filter support using 4 screws on each side. Do not tighten screws.

d) Attach the bottom filter support between the side plates using 2 screws on each side. Do not tighten screws

e) Attach the hood cover to the side plates using 3 screws on each side. Do not tighten screws.

f) Set hood assembly on a flat surface to insure all components are plumb and now tighten all screws.

3 - Attach the hood assembly over the outdoor air opening on the unit duct panel as follows :

On unit size 090, the flange of the hood cover must be inserted in under the unit top cover flange. One screw in the unit cover flange must be removed and one screw (at the right hand corner of the unit cover flange) needs only to be loosened to allow the notched flange of the hood cover to slide into place. Replace and tighten the 2 screws.

On unit sizes 120, secure the hood flange to the duct panel with 3 screws. Use holes in the hood cover flange as a template and drill 3 holes, 3.5 mm dia. into the duct panel.

On all units, attach the hood side plate flanges to the duct panel by drilling 6 holes, 3.5 mm dia. for each side plate at the dimples provided in the duct panel. Secure hood into position using 6 gasketed screws in each side plate.

4 - Secure the flange on the hood cover to the duct panel with 3 screws. Use holes in the cover flange as a template and drill 3 holes, 9/64" dia. into the duct panel.

5 - Insert two 1" filters into the centre of the hood, coming to rest in the centre filter support at the back of the hood.

Press filters up against the filter guide angles on the side plates and use 1 screw (B) on each side of hood to hold into position.

Insert two 1" filters into the bottom filter support per the same procedures as the centre filters.

Note : Install filters so that "Air Flow" arrows point upward, toward the unit.

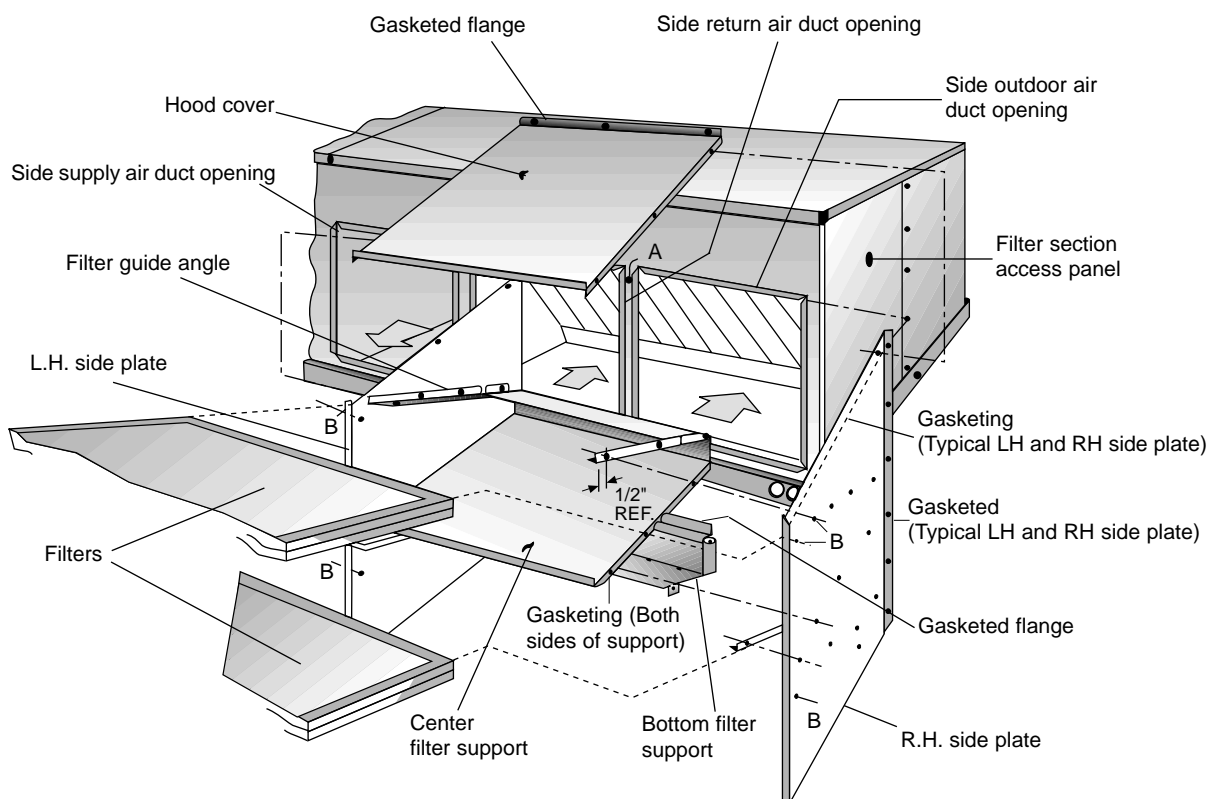
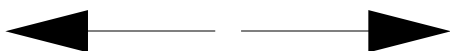

Fig. 22 - Economizer rain hood assembly (option) - DIG 090 to 150



19 - Installation (Cont'd)

19.7 - Optional economiser rain hood (models 180-240-300)

The following procedure should be used when assembling an economiser rain hood on to a unit. The outdoor and return air dampers, the damper actuator, the damper linkage, the outdoor and return air divider baffles and all the control sensors are factory mounted as part of the economiser option.

All of the hood components, and the hardware for assembling are packaged and located within the unit filter section. The economiser filters are shipped inside.

1 - With the filter section and the outdoor air compartment access panels removed, take out the hood components, filters and hardware described above. Loosen, but do not remove the two latches that secure the outdoor air access panel. Remove all screws from the post flange on each side of the opening.

2 - Assemble the rain hood per figure 15 as follows :

- a) Attach the LH and RH side plates of the bottom hood to the bottom holes provided in the unit post flanges. Do not tighten screws.
- b) Attach the bottom filter retainer between the two bottom side plates with two screws each side.
- c) Attach one filter support angle to the inside of each bottom side plate. Tighten screws in para. (a), (b) and (c).
- d) Insert one filter into the bottom hood by placing it on top of the filter angles and pressing it into the filter retainer.

Note : Install filter so that "air flow" arrows point upward, toward the unit.

- e) Place the bottom hood cover (with filter retainer) on top of the bottom side plates. Do not attach with screws until completion of para. (f).
- f) Attach the LH and RH side plates of the upper hood to the top of the bottom hood cover and to the upper holes provided in the unit post flanges. Tighten all screws.

Note : The lower flange of the upper hood side plates, the bottom hood cover and the upper flange of the bottom hood side plates will be secured together with four screws on each side.

- g) Attach one filter support angle to the inside of each upper side plate. Tighten screws.
- h) Insert one filter into the upper hood per the same procedure as in para. (d).
- j) Attach the upper hood cover to the top of the upper hood side plates with four screws each side.

On 240-300 units, a closure plate is provide for installation over the top of the outdoor air opening. Secure it to the unit post flanges with two screws on each side. The offset edge of the plate must be in the downward position. The top of the plate slips up under the unit cover flange. The top flange of the hood cover slips up under the offset edge of the closure plate and is secured with four screws. Tighten all screws.

On 180 unit, the top flange on the upper hood cover slips in under the unit cover flange when installing. The closure plate not required, may be discarded. Tighten all screws.

3 - Apply approximately a 1" long bead of caulking to the centre jointure on each side of the hood (at points marked "x" to prevent moisture from entering the unit.

4 - Re-tighten the screws on the two panel latches (indicated in para. 1) to prevent moisture from being drawn into the unit during operation. Place the latch on the RH side in a vertical position, and the latch on the LH side in a horizontal position which secures the supply air compartment access panel in place.

5 - Re-install the filter access panel on the unit. Position latches horizontally and re-tighten the screws.

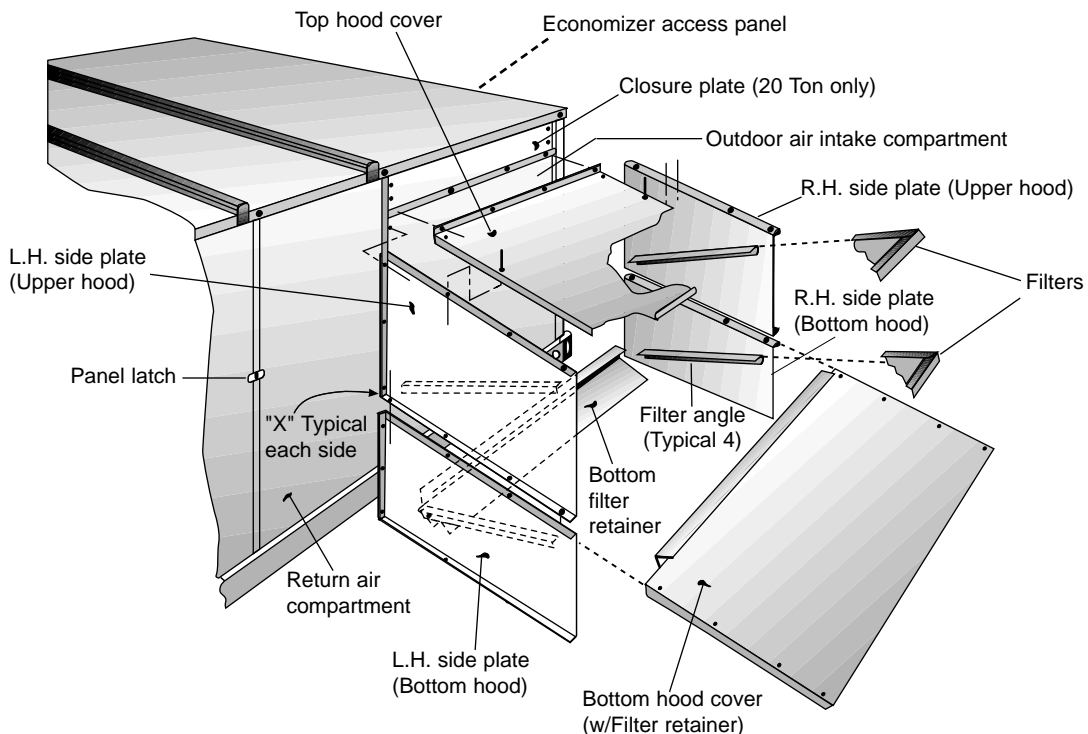

Fig. 23 - Economizer/motorised damper rain hood assembly (option)

19 - Installation (Cont'd)

19.8 - Power exhaust damper and rain hood option (models 180-240-300)

The following procedures should be used when assembling a power exhaust rain hood and damper on to a unit. Refer to figure 16. The exhaust fan, all supporting brackets, angles and the wiring are factory installed as part of the power exhaust option.

All of the hood components, including the bird screen, the screen mounting clips and the hardware for assembling are packaged along with the economiser hood components and are located within the unit filter section. The damper components are packaged separately and shipped inside of the outdoor air compartment beneath the economiser damper. Refer to figure 23 for unit access panel locations.

Note : The economiser/motorised damper hoods must be installed before proceeding with the power exhaust installation. Refer to installation procedures for the economiser hoods within this instruction.

- 1 - With the filter section access panel removed, take out the power exhaust and economiser hood components plus the hardware described above. Also remove the damper components from the outdoor air compartment.
- 2 - Loosen, but do not remove the panel latches that secure the various unit panels in place. Remove and discard the return air compartment panel on back of the unit.
- 3 - Remove the covering over the bottom return air duct opening inside of the unit. It consists of two pieces of heavy black cardboard taped in place for shipping which must be pulled through the exhaust fan on the back of the unit.
- 4 - Assemble the damper components (shown in detail "A") per the following procedures :

- a) Attach the upper and lower damper frame to one of the two identical side frames with the screws provided.

Note : The blade stop on the upper damper frame is different than the stop on the lower damper frame. Check the detail for proper positioning. Be sure that the flanges with holes on the damper frames will be toward the rear of the assembly.

- b) Turn this partially assembled frame over so that it rests on the side frame and insert the hinge pins of the three damper blades into the bushings provided in the side frame. (The blades will support themselves).

- c) Attach the remaining side damper frame in place by first inserting the damper hinge pins into the frame bushings and then secure this frame to the upper and lower frame.

- 5 - Mount the completed damper assembly at the holes provided on the back of the unit (over the exhaust fan).

Caution : Check for proper alignment and arrangement of damper blades. They should rotate away from the exhaust fan blades. The upper stop, lower stop and the screw in the sides should ALWAYS prevent the blades from rotating back into the fan. All hinge pins MUST move freely in the side bushings. Correct arrangement as needed. (Only if exhaust fan is present).

- 6 - Remove all screws from the unit post flange on the left side of the return air opening. Attach the hood side plate (LH side only) to the holes provided in the unit post flange.

- 7 - Attach the hood front panel on two sides - to the panel on the left side, per para. 6, and to the upper economiser panel, at the holes provided, on the right side.

- 8 - Attach the hood top cover at the holes on the left side panel flange, the front panel flange and on the right side - overlapping the economiser hood.

On 240-300 units, a closure plate is provided for installation over the top of the return air opening. Secure it to the unit post flanges with two screws on each side. The offset edge of the plate must be in the downward position.

The top of the plate slips up under the unit cover flange. The top flange of the hood cover slips up under the offset edge of the closure plate and is secured with three screws.

On 180 unit, the top flange of the hood cover slips up under the unit cover flange when installing. the closure plate - not required, may be discarded.

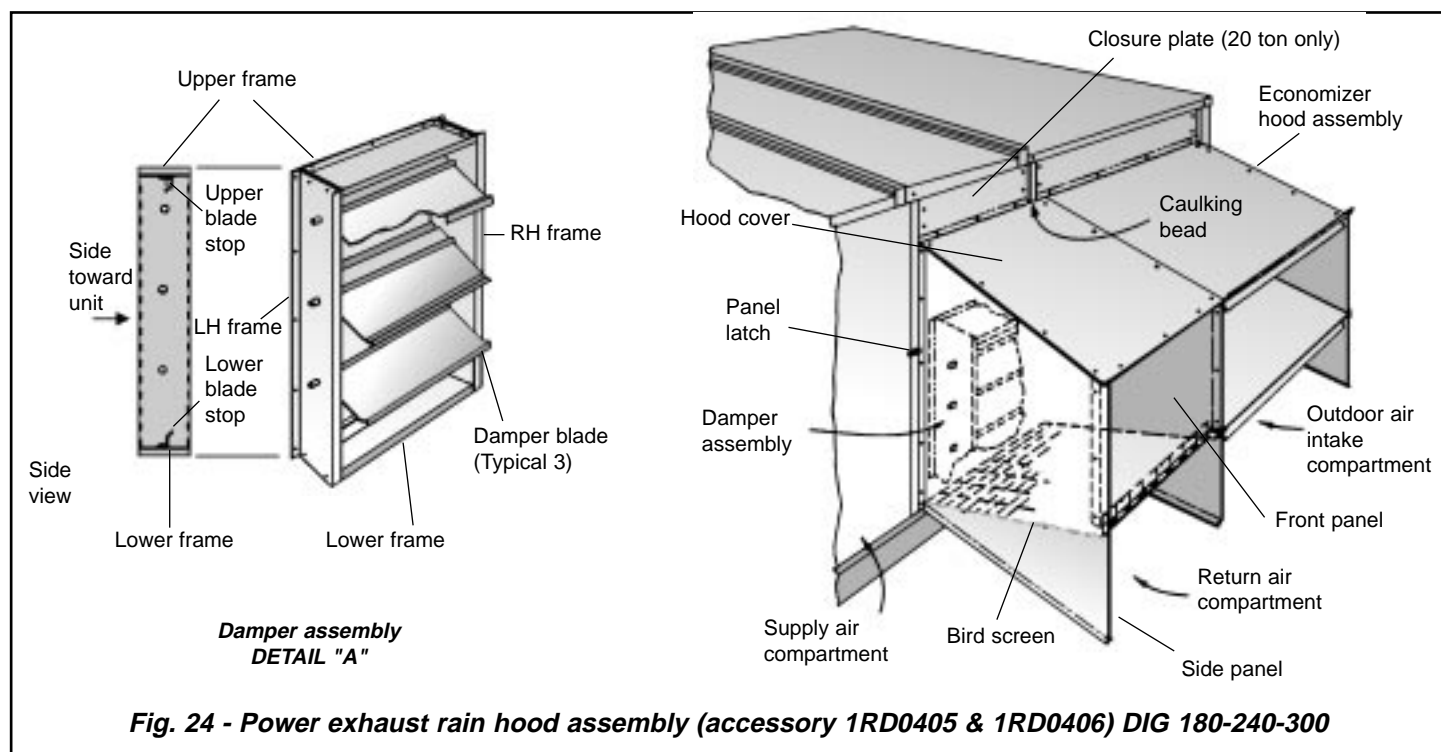

Fig. 24 - Power exhaust rain hood assembly (accessory 1RD0405 & 1RD0406) DIG 180-240-300

19 - Installation (Cont'd)

19.9 - Vent and combustion air hoods

The vent and combustion air hoods (with screens) are shipped attached to the blower housing in the blower compartment.

These hoods must be installed to ensure proper unit function. Both hoods must be fastened to the outside of the gas heat access panel with the screws provided in the bag also attached to the blower housing.

The screen for the combustion air intake hood is secured to the

inside of the access panel opening with three fasteners and the screws used for mounting the hood to the panel.

The top flange of this hood slips in under the top of the access panel opening when installing. Refer to figure 11.

The vent hood is installed by inserting the top flange of the hood into the slotted opening in the access panel, positioning the vent screen between the hood flanges and the access panel, and securing in place.

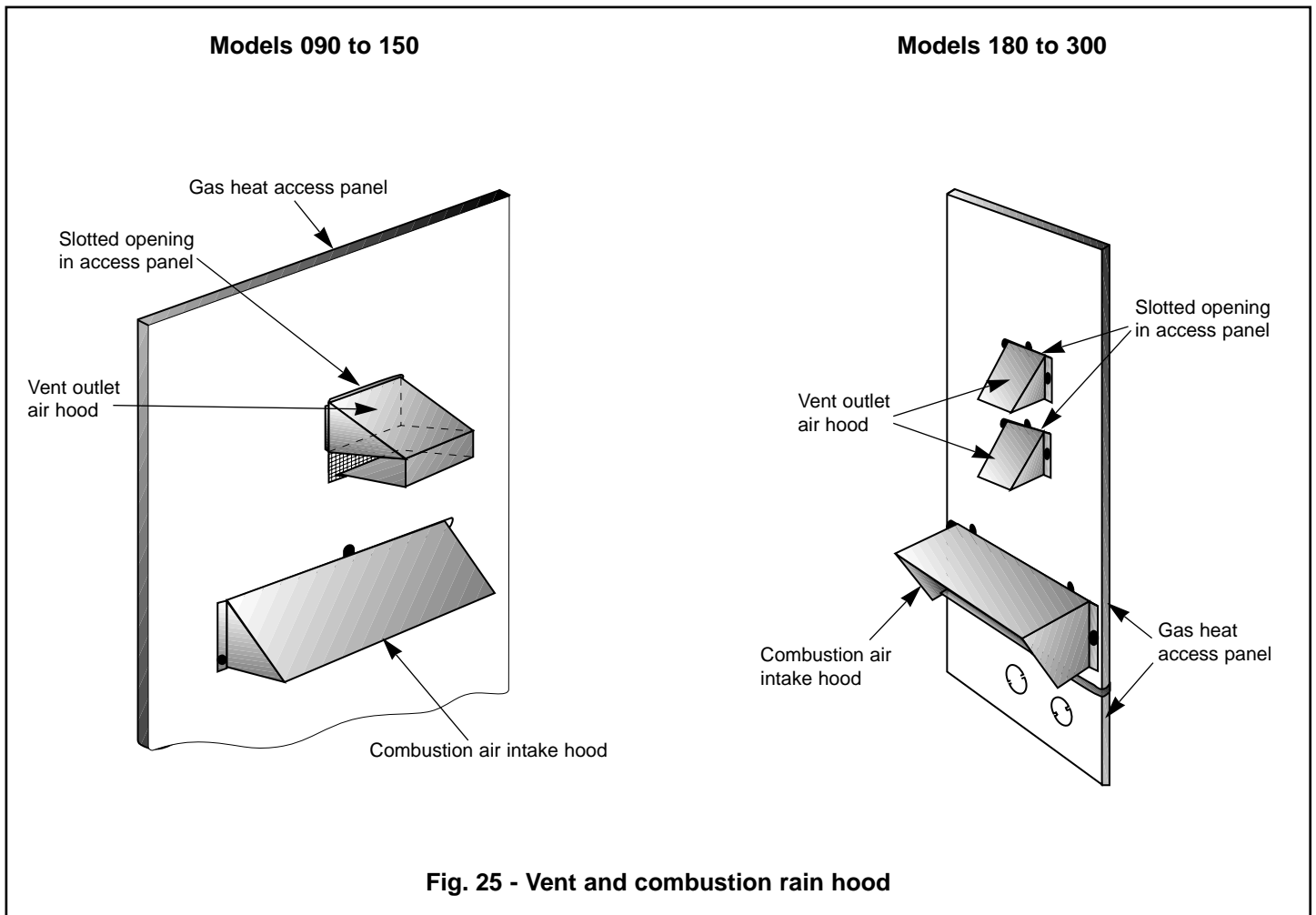

19 - Installation (Cont'd)

19.10 - Gas piping

Correct sizing of gas piping depends on the volume rate of gas flow required, specific gravity of the gas and the length of run. Local codes or gas company requirements should be followed when determining pipe size.

The heating value of the gas may differ with locality. The value should be checked with the local gas utility.

Note : There may be a local gas utility requirement specifying a minimum diameter for gas piping.

19.11 - Gas connection

The gas supply line can be routed through the knockouts located on the front of the unit or through the opening provided in the unit's base. Refer to figure 10 to locate these access openings. Typical supply piping arrangements are shown in figure 26.

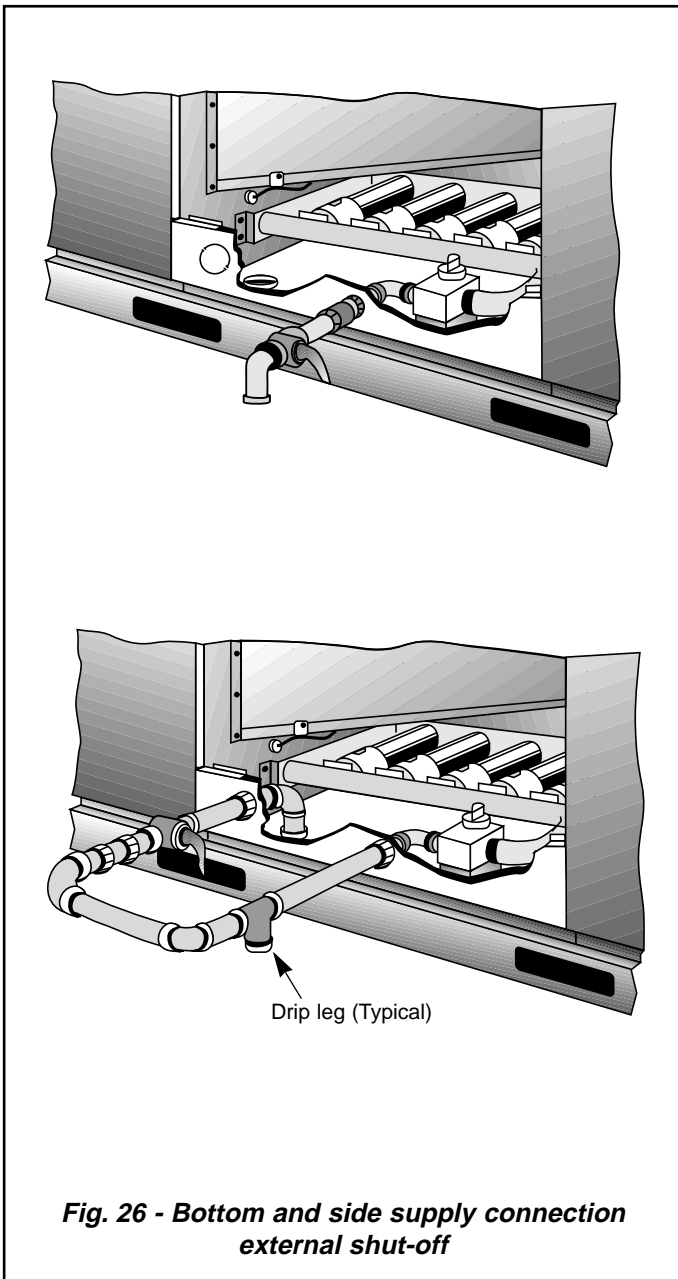

Fig. 26 - Bottom and side supply connection external shut-off

Two grommets are shipped in the blower compartment (in parts bag taped to the blower housing) of every unit with gas heat and should be used in the knockouts when the gas piping penetrates the front of the unit. After the gas supply piping has been installed, the bottom opening should be sealed to prevent water from leaking into the building.

19.12 - Gas piping recommendations

1. A drip leg and a ground joint union must be installed in the gas piping.
2. When required by local codes, a manual shut-off valve may have to be installed outside of the unit.
3. Use wrought iron or steel pipe for all gas lines. Pipe compound should be applied sparingly to male threads only.

Warning : Natural gas may contain some propane. Propane, being an excellent solvent, will quickly dissolve white lead or most standard commercial compounds. Therefore, a special pipe compound must be applied when wrought iron or steel pipe is used. Compounds complying with Standard BS6956 Part 5 or equivalent may be used.

4. All piping should be cleaned of dirt and scale by hammering on the outside of the pipe and blowing out the loose dirt and scale. Before initial start-up, be sure that all of the gas lines external to the unit have been purged of air.
5. The gas only should be a separate line and installed in accordance with all national, state and local or municipal safety codes. After the gas connection have been completed, open the main shut-off valve admitting normal gas pressure to the mains. Check all joints for leaks with soap solution or other material suitable for the purpose. Never use a flame.
6. The furnace and its individual manual shut-off valve must be disconnected from the gas supply piping system during any pressure testing of that system at test pressures in excess of 0.5 psig (3.5 kPa).

<i>Pipe connections</i>		
<i>Model</i>	<i>DIG 090-120-150</i>	<i>DIG 180-240-300</i>
<i>Gas connection female</i>	3/4"	1"

19 - Installation (Cont'd)

19.13 - Power wiring

The main switch is supplied with all the unit. Refer to electrical data to size the over current protection and wiring.

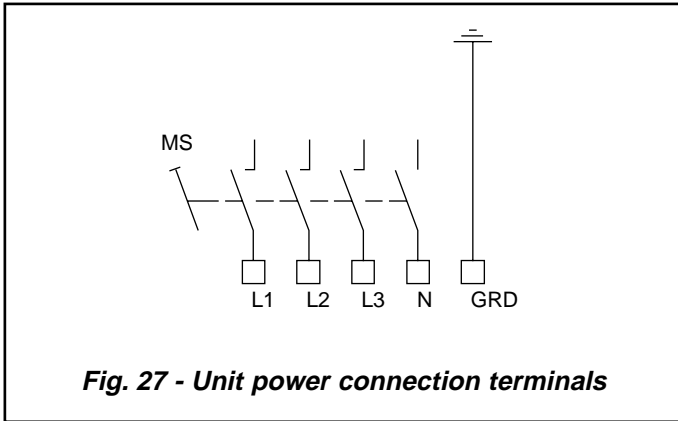

19.14 - Electromechanical thermostat

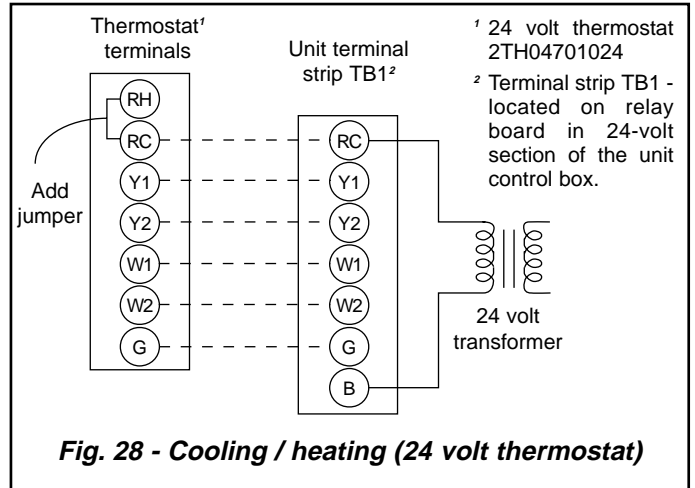

19.15 - Non programmable electronic thermostat ART TH 002 (DSL 700)

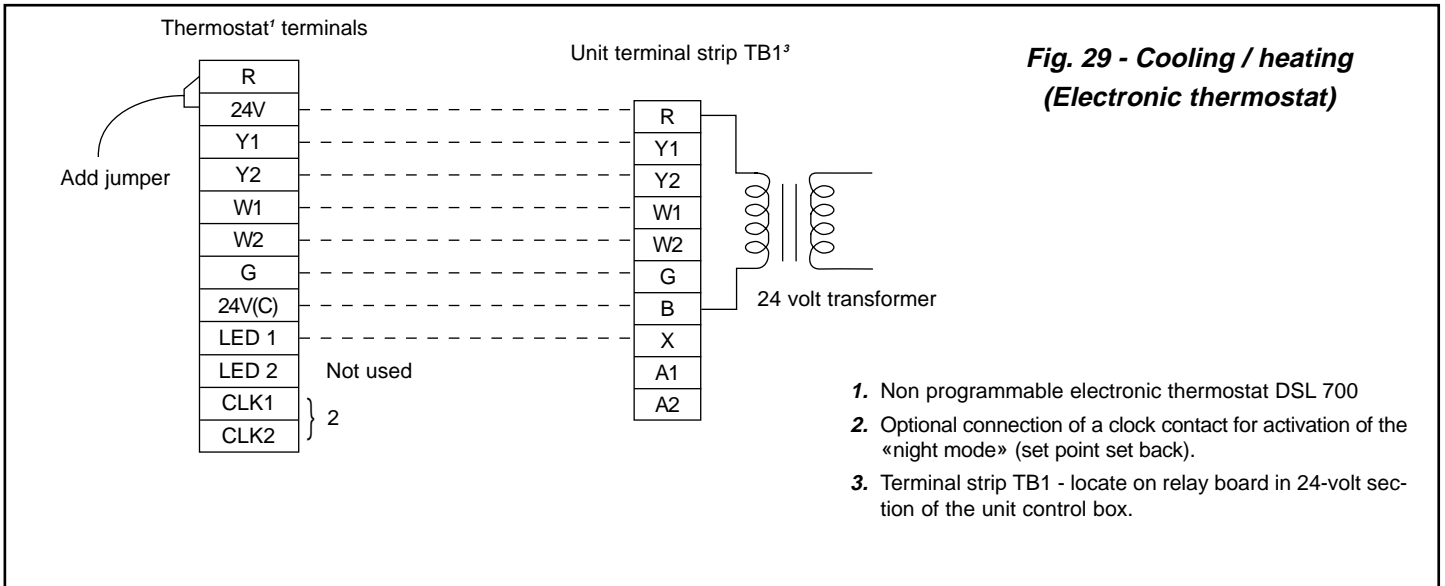

19.16 - Programmable thermostat (24 volts)

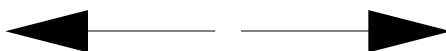
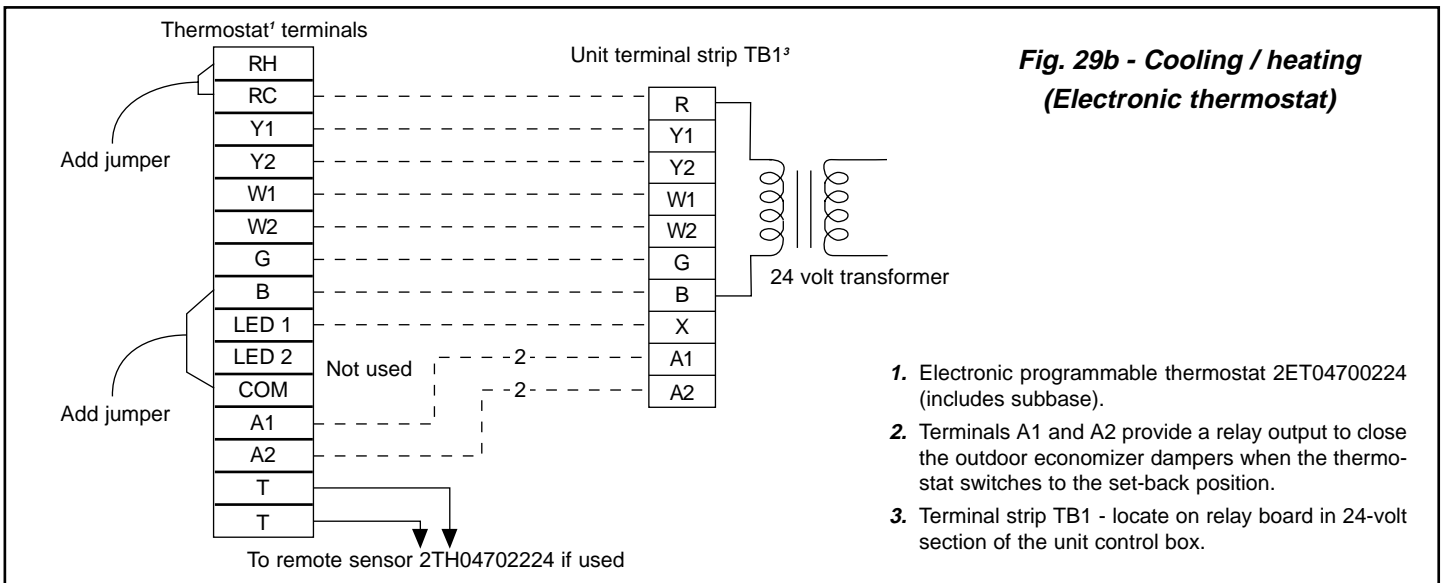

20 - Operation

The cooling section is a complete factory package utilizing an air-cooled condenser. The system is factory-charged with Refrigerant-22.

The compressors are hermetically sealed, internally sprung and base-mounted with rubber-insulated hold-down bolts. The compressors also have inherent (internal) protection. If there is an abnormal temperature rise in a compressor, the protector opens to shut down the compressor.

20.1 - Preliminary operation

After installation has been completed, energize the crankcase heaters for at least four hours before operating unit. After this initial warm-up, the compressors should be given three false starts (energized just long enough to make a few revolutions) with 5-7 minutes delay between each start before being put into full time service.

Note : Prior to each cooling season, the crankcase heaters must be energized at least 8 hours before system is put into operation.

20.2 - Cooling sequence of operation (Models 090 to 150)

Call for cooling, Y1 : Signal Y1 from the thermostat energizes the delay-on-make Timer TD1 and after a 4 second delay will energize the Compressor Contactor 1M, which operates the N°1 Compressor and Outdoor Fan.

Call for cooling, Y2 : If the thermostat is not satisfied by the Y1 signal and the conditioned space temperature continues to rise, Signal Y2 from the thermostat energizes the delay-on-make Timer TD2 and after a 10 second delay will energize the Compressor Contactor 2M, which operates the N°2 Compressor and Outdoor Fan.

20.3 - Heating sequence of operation (Models 090 to 150)

Call for heat, W1 : Signal W1 from the thermostat energizes Heat Relay RW1 and Time Delay Relay TDR. Heat Relay contact RW1 closes, energizing the Ignition Control circuitry. After approximately 15 seconds, Time Delay Relay contacts TDR close, energizing Blower Interlock Relay K5 (on the relay board). K5 contact K5-2 closes, energizing the Indoor Fan Contactor 3M, starting the indoor fan. Contact K5-1 opens, isolating the Indoor Fan Contactor 3M from the thermostat cooling circuit.

If gas supply pressure is above the Gas Pressure Switch (GS) setpoint, the Ignition Control (IC) is energized and the ignition sequence begins. Refer to figure 15 for typical gas valve piping.

Ignition sequence : Once contacts RW1 and GS are closed, the Ignition Control #1 verifies that the Air Pressure Switch (AS) contact is open. If so, the draft motor is energized via IC terminal 4, and a 40 second pre-purge sequence begins. After 5 seconds, if the AS contact does not close, IC will lock out.

Provided the AS contact closes, and once pre-purge is complete, the IC terminal A energizes the Ignition Transformer, which provides a high frequency arc at the ignitor (located at the right-hand burner). The main gas valve is energized at low gas rate via IC terminal 5. The left-hand burner is ignited and the ignition tube assembly ensures that all burners cross-light correctly. If the flame sensor (flame rectification type, located at the right-hand burner) does not provide sufficient current flow to IC terminal 2 within 5 seconds, the Ignition Control will lock out.

If ignition is successful, the Ignition Control continues to monitor the presence of flame. If the flame should extinguish, the Ignition Control will lock out. Similarly, should the Limit Switch LS1 or LS2 open due to over-temperature, or should the Burner Assembly Heatstat (RS) open due to high temperature in the gas control compartment, or should the Air Pressure Switch (AS) open due to combustion air failure (e.g. blockage or fan failure) the unit will lock out.

Call for heat, W2 : If the thermostat is not satisfied by the W1 signal and the conditioned space temperature continues to fall, the Heat Relay contact RW2 closes, energizing the gas valve high/low operator, which increases the burner manifold pressure to its higher value, causing the furnace to fire at high rate.

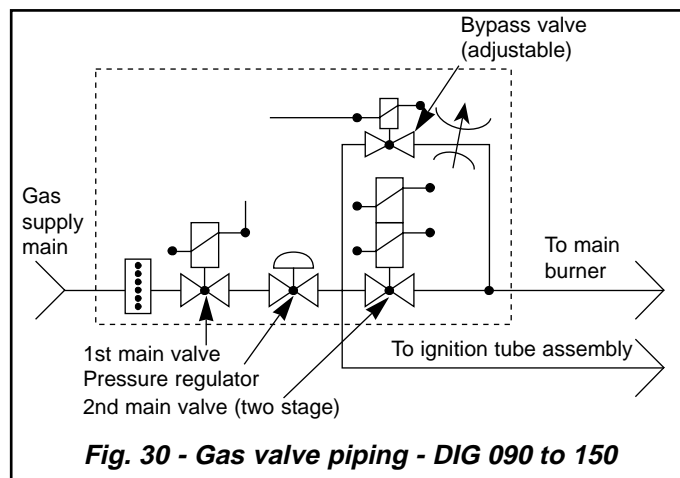

20.4 - Cooling sequence of operation (Models 180-240)

Call for cooling, Y1 : Signal Y1 from the thermostat energizes Cooling Relay RY-1. Contact RY-1 energizes Outdoor Fan Contactors 4M and 5M, and energizes the delay-on-make Timer TD1. After a 4 second delay, TD1 will energize the Compressor Contactor 1 M, starting the system #1 (tandem hermetic) Compressor. An additional signal is provided by the thermostat fan switch through thermostat terminal G, which energizes the Indoor Blower Contactor, 3M, starting the indoor blower motor.

Call for cooling, Y2 : If the thermostat is not satisfied by the Y1 signal and the conditioned space temperature continues to rise, Signal Y2 from the thermostat energizes Cooling Relay RY2. Contact RY2 energizes the delay-on-make Timer TD2, and after a 10 second delay will energize the Compressor Contactor 2M, starting the system #2 compressor (single hermetic on 180 Mhb unit; tandem hermetic on 240 Mhb unit).

20.4.1 - Cooling sequence of operation (Models 300)

When the room thermostat calls for "first-stage" cooling, the low voltage control circuit from "R" to "G" and "Y1" is completed to energise compressor n°1 and n°3 (66% capacity), condenser fan motor n°1, condenser fan motor n°2 (if the ambient temperature is above 16°C), and the supply air blower motor (if the fan switch on the room thermostat is set in the "AUTO" position).

When the thermostat calls for "second-stage" cooling, the low voltage control circuit from "R" to "Y2" is completed to energise compressor n°2.

Note: Unit is factory wired for two-stage cooling operation at 66/33% capacity, respectively. This can be altered for two-stage cooling at 33/66% capacity or three-stage cooling at 33/33/33% capacity per instructions on the unit wiring label.

After the thermostat is satisfied and opens, all components will stop simultaneously. The blower motor will continue to operate if the fan switch on the room thermostat is set in the "ON" position.

20.5 - Heating sequence of operation (Models 180-240-300)

Call for heat, W1 : Signal W1 from the thermostat energizes Heat Relay RW1 and Time Delay Relay TDR. Heat Relay contact RW1 closes, energizing the Ignition Control circuitry. After approximately 15 seconds, Time Delay Relay contacts TDR

20 - Operation (Cont'd)

close, energizing Blower Interlock Relay K5 (on the relay board). K5 contact K5-2 closes, energizing the Indoor Fan Contactor 3M, starting the indoor fan. Contact K5-1 opens, isolating the Indoor Fan Contactor 3M from the thermostat cooling circuit.

If the gas supply pressure is above the Gas Pressure Switch (GS) setpoint (GS is located on gas valve #1), Ignition Control (IC #1) is energized and the first stage ignition sequence will commence. Refer to figure 16, for typical gas valve piping.

Ignition sequence : Once contacts RW1 and GS are closed, the Ignition Control #1 verifies that the Air Pressure Switch (AS) contact is open. If so, the draft motor is energized via IC#1 terminal 4, and a 40 second pre-purge sequence begins. After 5 seconds, if the AS contact does not close, IC#1 will lock out. Provided the AS contact closes, and once pre-purge is complete, the IC#1 terminal A energizes the Ignition Transformer #1, which provides a high frequency arc at the system #1 ignitor (located at the right-hand burner of the upper manifold). IC#1 terminal 5 energizes the main gas valve #1 (GV1) at low gas rate via IC terminal 5. The right-hand burner is ignited and the ignition tube assembly ensures that all burners cross-light correctly. If the system #1 flame sensor (flame rectification type, located at the left-hand burner of the upper manifold) does not provide sufficient current flow to IC #1 terminal 2 within 5 seconds, the Ignition Control #1 will lock out.

If ignition is successful, Ignition Control #1 continues to monitor the presence of flame. If the flame should extinguish, Ignition Control #1 will lock out. Similarly, should either Limit Switch LS1 or LS2 open due to over-temperature, or should the Burner Assembly Heatstat (RS) open due to high temperature in the gas control compartment, or should the Air Pressure Switch (AS) open due to combustion air failure (e.g. blockage or fan failure) Ignition Control #1 will lock out.

Call for heat, W2 : If the thermostat is not satisfied by the W1 signal and the conditioned space temperature continues to fall, the Heat Relay contact RW/2 closes, initiating the second stage ignition sequence. Ignition Control #2 (IC#2) operates identical to IC#1, described above, except as noted :

System #2 ignition sequence : Power is supplied to Ignition Control #2 from IC#1 terminal 6. Ignition Control #2 verifies that the Ignition Sequence Relay (RIS) contact is open. If so, RIS is energized via IC#2 terminal 4 and a 40 second dwell period begins.

After 5 seconds, if the RIS contact has not closed, IC#2 will lock out. Ignition Transformer #2 provides a high frequency arc at the system #2 ignitor (located at the left-hand burner of the lower manifold). The left-hand burner is ignited and the ignition tube assembly ensures that all burners cross-light correctly.

If the System #2 Flame Sensor (flame rectification type, located at the right-hand burner of the lower manifold) does not provide sufficient current flow to IC#2 terminal 2 within 5 seconds, Ignition Control #2 will lock out.

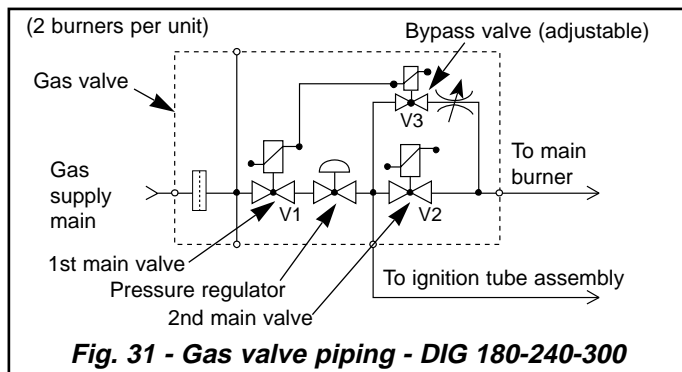

20.6 - Economizer with dual enthalpy sensor

When the room thermostat calls for "first-stage" cooling, the low voltage control circuit from "R" to "G" and "Y1" is completed. The "R" to "G" circuit energizes the blower motor (if the fan switch on the room thermostat is set in the "AUTO" position) and drives the economizer dampers from fully closed to their minimum position. If the enthalpy of the outdoor air is below the indoor enthalpy "Y1" energizes the economizer. The dampers modulate to maintain a constant supply air temperature as monitored by the discharge air sensor. If the outdoor air enthalpy is above the setpoint, "Y1" energizes compressor #1 and compressor #3 (DIG 300), outdoor fan motor #1, and outdoor fan motor #2 (if the ambient temperature is above 16°C on units DIG 180-240-300).

When the thermostat calls for "second-stage" cooling, the low voltage control circuit from "R" to "Y2" is completed. If the enthalpy of the outdoor air is below the setpoint of the enthalpy controller (i.e., first stage has energized the economizer), "Y2" energizes compressor #1 and compressor #3 (DIG 300). If the outdoor air is above the setpoint, "Y2" energizes compressor #2.

After the thermostat is satisfied and opens, all components stop simultaneously. The blower motor continues to operate if the fan switch on the room thermostat is set in the "ON" position.

20.7 - Enthalpy setpoint adjustment

Remove the economizer access panel from the unit to check the following adjustments. Loosen but do not remove the two panel latches.

For dual enthalpy operation, carefully turn the setpoint adjusting screw fully clockwise past the "D" setting.

To check that the damper blades move smoothly without binding, carefully turn the minimum position adjusting screw fully clockwise and then energize and de-energize terminals "R" to "G". With terminals "R" to "G" energized, turn the minimum position screw counterclockwise until the desired minimum position has been attained.

Replace the economizer access panel. Reposition the two latches horizontally and retighten the screws.

Caution : Extreme care must be exercised in turning both the setpoint and minimum position adjusting screws to prevent twisting them off.

20.8 - Economizer with exhaust fan option available with DIG 180-240-300

This system operates as specified above with one addition. The power exhaust motor is energized whenever the economizer is chosen by the enthalpy sensor for first stage cooling, "Y1". As always, the "R" to "G" connection provides minimum position but does not provide power exhaust operation.

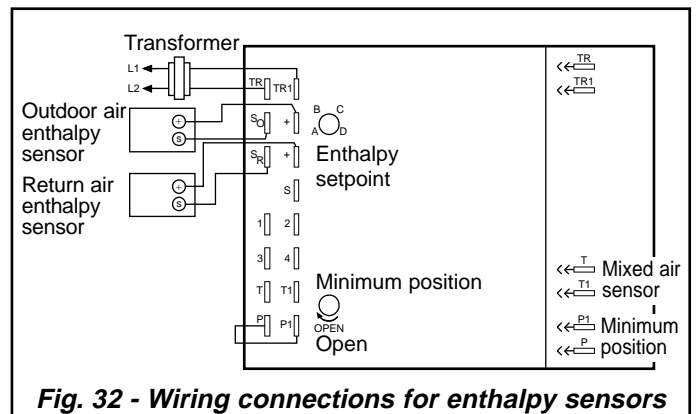

20 - Operation (Cont'd)

20.9 - Motorized outdoor air dampers

This system operation is the same as the units with no outdoor air options with one exception. When the "R" to "G" circuit is complete, the motorized damper drives open to a position set by the thumbwheel on the damper motor. When the "R" to "G" circuit is opened, the damper spring returns fully closed.

20.10 - Heat anticipator setpoint

This adjusting is only necessary on the electromechanical thermostat.

Furnace	Anticipator setpoint	
	1st stage	2nd stage
N320	0.27 amp	0.08 amp

It is important that the anticipator setpoint be correct. Too high of a setting will result in longer heat cycles and a greater temperature swing in the conditioned space. Reducing the value below the correct setpoint will give shorter "ON" cycles and may result in the lowering of the temperature within the conditioned space.

20.11 - Pre-start check list (gas burner)

Complete the following checks before starting the unit.

1. Ensure that shut-off valves have been installed at inlet to the unit and their whereabouts are known. Ensure that the air vent and combustion air hoods have been correctly installed.
2. Verify that gas supplied is as required and identified on the unit nameplate. Also check that orifice sizes correspond to the information on the nameplate.
3. Purge air from the unit gas run up to and including the gas valve. Bleed the air from the "Pa" pressure test point of the valve. When all the air has been expelled, reseal the "Pa" connection.
4. While supplying gas to the unit and the gas valve is under pressure, check piping for gas leakage using soap and water solution.
5. Use the designated pressure tapping locations to locate measuring equipment, e.g. manometer or low pressure gauge to enable operating pressures to be monitored.
6. Check the supply gas pressure. It must be within the limits shown on rating nameplate. Supply pressure should be checked with all gas appliances in the building at full fire. At no time should the standby gas line pressure exceed 25 mbar, nor the operating pressure drop below 12.5 mbar for natural gas units. If gas pressure is outside the limits, contact the local gas utility for corrective action.
7. Check that inlet gas pressure switch functions at the pressure selected on the variable dial, normally 5 IWG (12.5 mbar). To set the switch, remove the transparent hood and set the switching point on the graduated adjustment wheel. The nominal value on the scale corresponds to the actual value with a tolerance of $\pm 15\%$.
8. Check that the setting on the heat exchanger exhaust air pressure switch is set at 0.5 mbar.
9. Verify that all electrical connections of the gas chamber are secure.

20.12 - Post-start check list (gas)

After the entire control circuit has been energized and the heating section is operating, make the following checks :

1. Check for gas leaks in the unit piping as well as the supply piping.

2. Check for correct manifold gas pressures. See "Checking Gas Input".
3. Check the supply gas pressure. It must be within the limits shown on rating nameplate. Supply pressure should be checked with all gas appliances in the building at full fire. At no time should the standby gas line pressure exceed 25 mbar, nor the operating pressure drop below 12.5 mbar for natural gas units. If gas pressure is outside these limits, contact the local gas utility for corrective action.
4. Check combustion products at flue outlets for CO, CO² and NOX if possible. CO must be less than 0.1% i.e. 1000 ppm. Verify that CO/CO² ratio is less than 0.02.

20.13 - Manifold gas pressure adjustment Models 090-120-150

Adjustments to the high and low gas flows may be made by turning the adjusting screws on the automatic gas valve shown in figure 18 per the following sequence. Set the valve to the tabulated values per table below depending on the size of furnace and type of gas utilized.

1. Set the internal pilot (A) to maximum rate (+).
2. Set the fast lift operator (B) one turn back from fully clockwise.
3. With the second stage operational, slightly loosen the fillister head screw on the high fire operator (C) and set the high fire operator to full open. Adjust the main regulator (D) to the tabulated value. Reduce the high fire operator (C) to yield the pressure specified.
4. With only the first stage operational, now set the low fire adjustment (E) to the pressure specified. Tighten the fillister head screw to lock the settings permanently. Close the small cover over the main regulator.
5. Using an exhaust gas analyzer, check the products of combustion at the flue outlet for CO, CO² and NOX if possible.

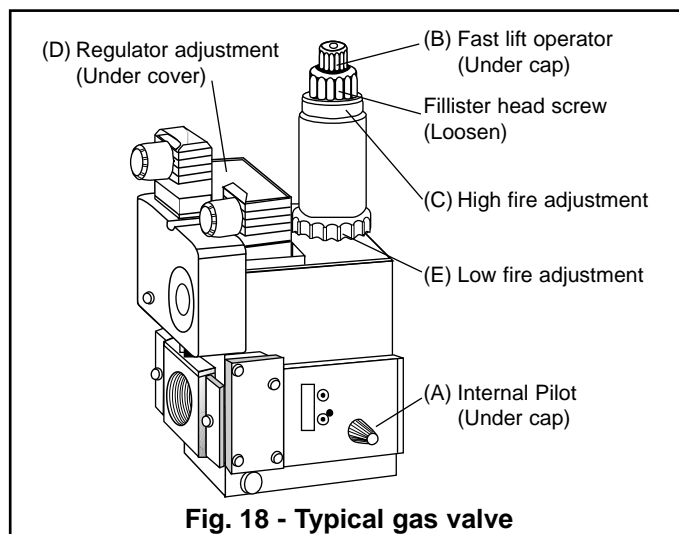

Fig. 18 - Typical gas valve

Model	Gas Family	Gas valve setting mbar			Limit switch setting °C	
		Main regulator	High fire	Low fire		
DIG 090	G20	10.5	9.9	4.9	82	93
	G25	15.2	5.9	7.3	82	93
DIG 120-150	G20	10.5	9.9	4.9	82	93
	G25	15.2	5.9	7.3	82	93
DIG 180	G20	10.5	9.9	-	82	93
	G25	15.2	14.6	-	82	93

20 - Operation (Cont'd)

20.14 - Manifold gas pressure adjustment Models 180-240-300

Adjustments to the manifold pressures may be made by turning the adjusting screws on each automatic gas valve as shown in figure 19 per the following sequence. Set each valve to the tabulated values per table on previous page, depending on the size of furnace and type of gas utilized.

1. Set the internal pilot (A) to five turns open from fully clockwise.
2. Set the fast lift operator (B) one turn back from fully clockwise.
3. With the gas valve in operation, slightly loosen the fillister head screw on the 2nd main valve operator V2 (C) and set the operator to full open. Adjust the main regulator (D) to the tabulated value. Reduce operator (C) to yield the manifold pressure specified.
4. Tighten the fillister head screw to lock the settings permanently. Close the small cover over the main regulator.

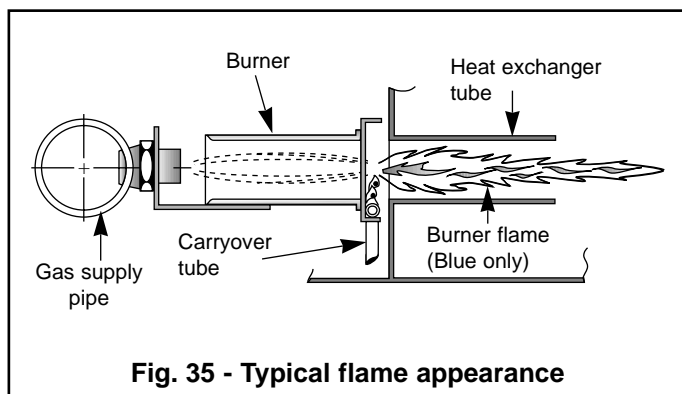
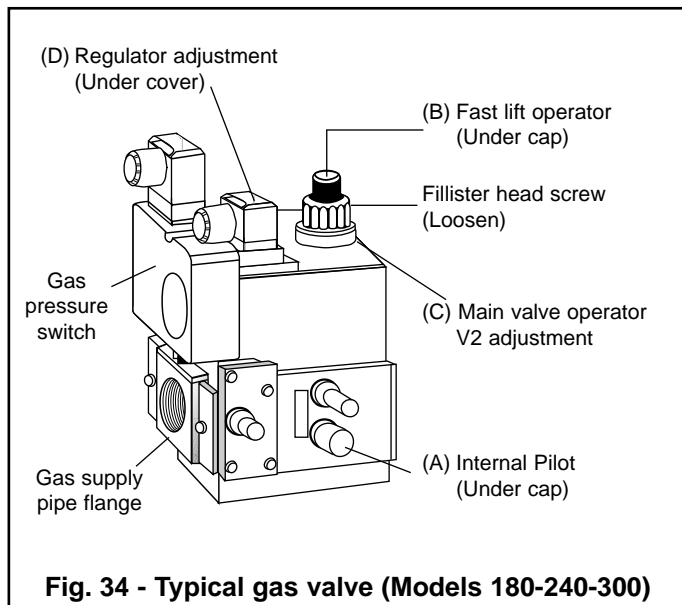

20.15 - Belt drive blower

All units have belt drive single-speed blower motors. The variable pitch pulley on the blower motor can be adjusted to obtain the desired supply air flow.

Note the following :

1. The supply airflow must be within the limitations.
2. Pulleys can be adjusted in half turn increments. (6 turns maxi).

3. The tension on the belt should be adjusted as shown in figure 35.

Start the supply air blower motor. Adjust the resistances in both the supply and the return air duct systems to balance the air distribution throughout the conditioned space. The job specifications may require that this balancing be done by someone other than the equipment installer.

20.16 - To check the supply air volume after the initial balancing has been completed (models 090 to 150)

- a. Drill two 8 mm holes in the side panels as shown in figures 21/22.
 - b. Insert at least 200 mm of 6 mm tubing into each of these holes for sufficient penetration into the air flow on both sides of the evaporator (or indoor) coil.
- Note :** The tubes must be inserted and held in a position perpendicular to the air flow so that velocity pressure will not affect the static pressure readings.
- c. Using an inclined manometer, determine the pressure drop across a dry indoor coil. Since the moisture on an indoor coil may vary greatly, measuring the pressure drop across a wet coil under field conditions would be inaccurate. To assure a dry coil, the compressor should be deactivated while the test is being run.
 - d. Knowing the pressure drop across a dry coil, the actual volume through the unit can be determined from the curve in page 18.

Caution

Procedure for adjusting belt tension :

1. Loosen four nuts (top and bottom) (A).
2. Adjust by turning (B).
3. Never loosen nuts (C).
4. Use a belt tension checker to apply a perpendicular force to one belt at the midpoint of the span as shown. The deflection force should be applied until a specific deflection distance of 4 mm (5/32") is obtained.

To determine the deflection distance from normal position, use a straight edge from sheave to sheave as a reference line. The recommended deflection force is as follows :

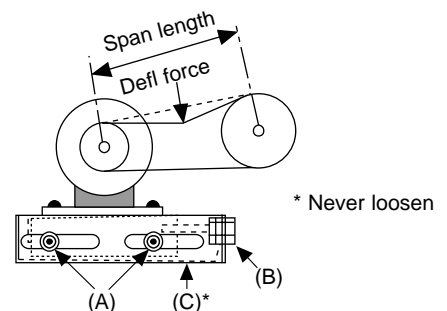

Tension new belts at the max. deflection force recommended for the belt section. Check the belt tension at least two times during the first 24 hours of operation. Any re-tensioning should fall between the min. and max. deflection force values.

5. After adjusting, re-tighten nuts (A).

Fig. 36 - Belt adjustment

20 - Operation (Cont'd)

20.17 - To check the supply air volume after the initial balancing has been completed (models 180-240-300)

The procedure is same as above for smaller units, except holes do not need to be drilled in panels.

Remove the two dot plugs from the blower motor and filters access panels and insert tubing.

Warning : Failure to properly adjust the total system air quantity can result in extensive blower damage.

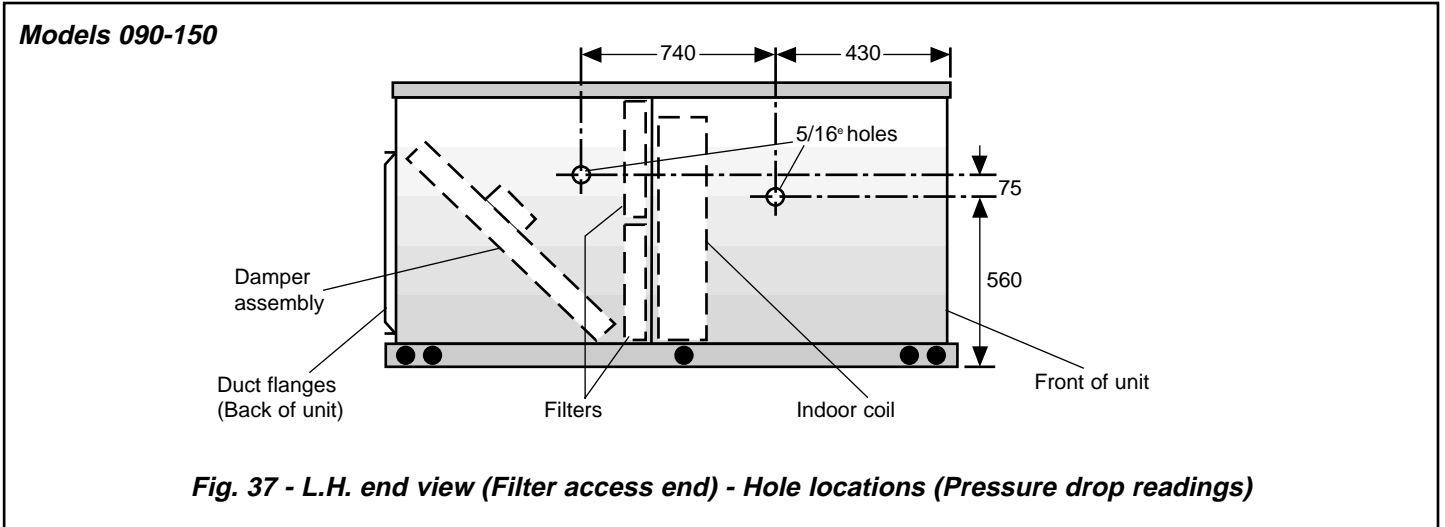

21 - System Protections

21.1 - Lockout control

21.1.1 - Cooling lockout

If the High Pressure Control (HP1), Low Pressure Control (LP1), or the Low Evaporator Temperature Control (FS1) open during compressor operation, the compressor #1 Lockout Relay K3 is energized. Contact K3-1 opens which maintains the energized status of K3 after contacts HP1, LP1 or FS1 re-close. In addition, contact K3-2 closes, energizing Relay Board terminal X to provide an external lock-out signal. Even though contactor 1M is in series with relay K3, the large voltage drop across the high-impedance relay K3 prevents 1M from energizing. The lock-out condition is cleared at the thermostat by removing and restoring Signal Y1, i.e. turning the thermostat to "OFF", then back to "ON".

The Lockout Relay K4 circuitry for refrigerant circuit N°2 functions as described for circuit N°1 above.

21.1.2 - Heating lockout

Should Ignition Control (IC#1) lock out due to the actuation of any device LS2 (Auto-Reset Limit Switch), RS (Burner Heatstat) or AS (Air Pressure Switch), the neon lamp on the IC#1 cover will light, and IC#1 will stay locked out until manually reset. IC#1 will not reset in the event of interruption and restoration of power, and cannot be reset at the room thermostat. Should the Manual Reset Limit Switch (LS1) open (LS2 has a lower setpoint and should normally open first) the Ignition Control will not function until LS1 is manually reset. Access to LS1 is via the supply air

access panel (for downflow installations or via the patch-plate on the condenser partition (for sidewall installations).

Ignition Control IC#2 will lock out in case of flame failure, or if the RIS (Ignition Sequence Relay) contact does not sequence correctly (e.g. stuck open or closed. Lock-out of IC#2 will not cause IC#1 to lock out).

21.1.3 - Low gas pressure

If gas supply pressure falls below the gas pressure switch (GS) setpoint, power to IC#1 (and IC#2 is interrupted, ceasing operation).

The furnace will automatically reset once the supply gas pressure increases above the switch setpoint, and the ignition sequence will be re-initiated.

21.1.4 - Motor overload protection

Each hermetic compressor motor and outdoor fan motor is protected against overload by an internal line-break overload protector. The protector will reset automatically after the motor cools sufficiently.

The indoor blower motor is protected by a Class 10 thermal-type overload relay, set to the full load amp rating of the blower motor.

In the event of excessive current draw on all three phases, or in the case of single-phasing of the motor, the Blower Overload Relay contact (BOR) opens, interrupting power to the Indoor Blower Contactor, 3M. The overload relay will reset automatically after the elements cool sufficiently.

22 - Maintenance

Caution : Prior to any of the following maintenance procedures, shut off all power to the unit to prevent personal injury.

22.1 - Filters

Inspect once a month. Replace disposable or clean permanent type as necessary. Do not replace permanent type with disposable. The dimensional size of the replacement filter must be the same as the replaced filter.

22.2 - Motors

DIG 090 to 150 : Indoor fan and outdoor fan motors are permanently lubricated and require no maintenance.

DIG 180-240-300 : Outdoor fan motors are permanently lubricated and require no maintenance.

Indoor blower motor and drive : The indoor blower motor features ball-bearings that do not require periodic lubrication. Periodic lubrication of the motor and bearings can extend the life of components but is optional.

Caution : Damage can occur if the bearings are overlubricated. Use grease sparingly.

Warning : Perform all maintenance operations on the blower motor with power disconnected from the unit. Do not attempt to lubricate bearings with the unit in operation.

On an annual basis, check the motor for accumulations of dust, etc. that may block the cooling slots in the motor shell. Check for loose, damaged or misaligned drive components. Check that all mounting bolts are tight. Replace defective parts as required.

If desired, every three years remove both pipe plugs at each end shell and clean out any hardened grease or foreign matter. Replace one plug on each end with a clean grease fitting. Using a low pressure grease gun, pump grease (Chevron SR1-2 or equivalent) into the bearing cavity until new grease shows at the open port. Do not over-lubricate. Run the motor for ten minutes until excess grease is purged from the cavity. Replace the plugs.

On 240-300 units only, units are supplied with blower shaft bearings that do not require maintenance but may be relubricated if desired. Every three years, using a low-pressure grease gun, pump grease into the bearing grease fitting until grease just begins to show at the seals. Do not overlubricate. Use any lithium base grease recommended for ball bearing service.

22.3 - Outdoor coil

Dirt should not be allowed to accumulate on the outdoor coil surface or other parts in the air circuit. Cleaning should be as often as necessary to keep coil clean. Use a brush, vacuum cleaner attachment, or other suitable means. If water is used to clean coil, be sure power to the unit is shut off prior to cleaning.

Note : Exercise care when cleaning the coil so that the coil fins are not damaged.

Do not permit the outdoor air discharge to be obstructed by overhanging structures or shrubs.

22.4 - Burner

Periodically (at least annually at the beginning of each heating season) make a visual check of the main burner flame.

To clean burners : Remove them from the furnace as explained in "Burner Instructions". Clean burners with hot water applied along top of the burner.

Combustion air discharge : Visually inspect discharge outlet periodically to make sure that the buildup of soot and dirt is not excessive. If necessary, clean to maintain adequate combustion air discharge.

22.5 - Cleaning flue passages and heating elements

With proper combustion adjustment the heating element of a gas fired furnace will seldom need cleaning. If the element should become sooted, it can be cleaned as follows :

1. Remove the burner assembly as outlined in "Burner Instructions".
2. Remove the roof over the gas heat section.
3. At the top plate from the top draft blower housing and the top draft blower wheel.
4. Remove the screws holding the top of the flue collector box. Carefully remove the top of the flue collector box without ripping the adjacent insulation. Then remove the center divider plate separating the upper and lower flue boxes.
5. On the inside of the flue collector box, remove the flue baffles from the tube interiors. Note the last bend of the baffle fits tightly against the tube forcing the end of the baffle to lock into the tube collar. This collar is formed when the tube is expanded into the end sheet. To remove, move the end of the baffle toward the center of the tube releasing the end of the baffle from the tube collar, then pull straight out of the tube. Refer to figure 24.
6. Using a wire brush on a flexible wand, brush out the inside of each heat exchanger from the burner inlet and flue outlet ends.
7. Brush out the inside of the flue collector box and the flue baffles.
8. Run the wire brush down the vent hoods from the flue collector end.
9. If soot build-up is particularly bad, remove the vent motor and clean the wheel and housings. Run the wire brush down the flue extensions at the outlet of the vent housings.
10. After brushing is complete, blow all brushed areas with air or nitrogen. Vacuum as needed.
11. Replace parts in the order they were removed in Steps 1 thru 4.
12. When replacing the center and top of the flue collector box, be careful not to tear the adjoining insulation.
13. Ensure that all seams on the vent side of the combustion systems are air tight. Apply a high temperature (260°C) sealing compound where needed.

Note : One end of each flue baffle is provided with a sharper bend than the other end - this sharper bend must be positioned at the tube exit so that its spring action will hold it in place.

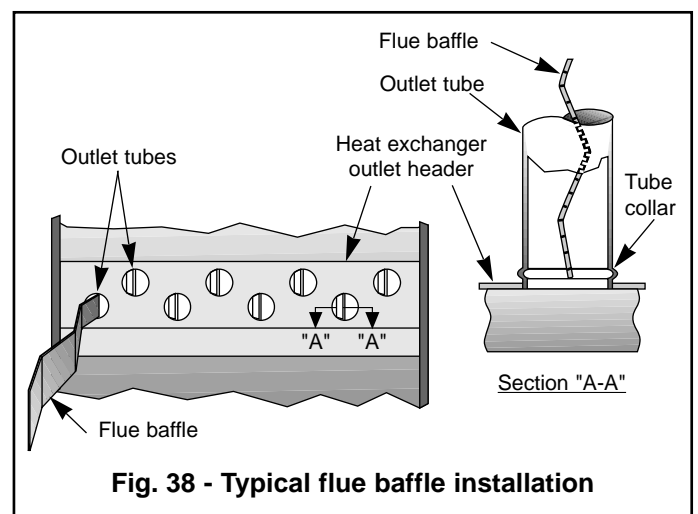

23 - Fault Analysis

23.1 - General

Before analyzing faults in depth, first verify that the thermostat is calling for Cooling or Heating, and that electrical power supply to the unit has not been interrupted by open fuses disconnect switches, etc. Verify that thermostat and field control wiring are functioning properly.

Supply air failure will normally cause other faults. In cooling, loss of supply air will cause compressor lockout due to low evaporator temperature.

In heating, supply air failure will actuate the high limit switch and cause ignition control lockout. Investigate and correct supply air failure before analyzing other fault conditions.

Caution : Fault Analysis typically requires the electrical system to be energized while evaluating components and their operation. Avoid energized conductors. Check for voltage using a Voltmeter with insulated probes adequate for the voltages involved. Never assume circuits are de-energized!

23.2 - Probable fault causes and suggested corrective action

If unit operates but is unable to satisfy thermostat, refer directly to Sec. 7.

Refer to Figure 39 for "Fault Analysis Flow Chart".

23.2.1 - No cooling; Supply air present; 1M/2M contacts closed

- A. Compressor motor protector open. Wait for protector to reset.
- B. One or more open phases. Check power supply.
- C. 1M/2M Contactor contacts damaged. Check for voltage on load side and replace contactor(s) if necessary.
- D. Loose or damaged power leads on line or load side of contactors. Check wiring.
- E. Compressor motor failed.
- F. Loss of charge.

23.2.2 - No cooling; Supply air present; 1M/2M contacts open.

Lockout condition due to high or low discharge pressure or low suction temperature. External lockout alarm, if present, will be activated. Reset lockout at thermostat and monitor subsequent events. If unit again locks out, call for service.

Caution : Do not repeatedly reset from lock-out condition or equipment damage may occur.

- B. Faulty connection at Contactor 1M/2M coil, or coil failed. Repair or replace.
- C. Time Delay-On-Make Relay TD1/TD2 faulty.
- D. Relay board contacts K3-1 or K4-1 open when relay is de-energized. Replace relay board.
- E. No signal at relay board :
 - i. Without Economizer :
 - Faulty economizer jumper plug or wiring.
 - ii. With Economizer :
 - a. Faulty economizer logic module or wiring.
 - b. Thermostat set to unoccupied mode.
 - c. Occupied relay coil or contacts faulty.

23.2.3 - No cooling/heating; No supply air present; 3M contacts closed.

- A. One or more open phases. Check fuses and power supply.
- B. 3M Contactor contacts damaged. Check for voltage on load

side and replace contactor if necessary.

- C. Loose or damaged power leads on line or load side of contactors. Check wiring.
- D. Supply air motor failed.
- E. Drive belt broken or drive pulley loose. Check drive and blower assembly.

23.2.4 - No cooling/heating; No supply air present; 3M contacts open

- A. One or more open phases. Check fuses and power supply.
- B. No 24VAC control power. Reset 24V circuit breaker if tripped. Check control transformer 1T.
- C. No 220-240V supply to transformer 1T due to open fuse 1 FU.
- D. Overload relay open due to overcurrent.

Note : Relay selector should normally be set to "auto-reset" in which case relay will reset after a short period of time. If relay is set to "manual" it will require resetting by pushing the reset button on the relay. Reset and select "auto-reset".

- E. Overload relay open and will not reset. Replace relay.
- F. Faulty connection at 3M contactor coil, or coil failed. Repair or replace.
- G. **Cooling mode** - Relay board contacts K5-1 open. Replace relay board.
- H. **Heating mode** - Time delay relay contacts open. Check wiring. If voltage is present at TDR heater but contacts do not close after time delay period, replace TDR.
- I. **Heating mode** - Time delay relay contacts closed, relay K5 energized, but relay board contacts K5-2 open. Replace relay board.

23.2.5 - No heating; Supply air present; Ignition control locked-out.

Check Ignition Control program indicator ("color wheel") to determine point at which IC has locked-out. Wheel rotates in clockwise direction. Triangular pointer indicates position at which lock-out has occurred.

- A. End of White/Start of Blue Sector : indicates Air Pressure Switch (AS) contacts not open prior to pre-purge sequence. Check AS and wiring, repair or replace if necessary.
- B. Narrow Red Line in Blue Sector indicates Air Pressure Switch (AS), Limit Switch (LS2) or Burner Assembly Heatstat (RS) contacts not closed after start of pre-purge. Check LS2 and RS contacts for continuity. Verify draft motor operation and check AS action. Inspect AS tubing and flue outlet for blockage. Check that pressure generated by combustion air blower is greater than pressure setting on AS. Check gas valve coil W1 for electrical continuity.
- C. Blue Sector : indicates air supply proved but subsequently failed. Check for intermittent failures per item B.
- D. End of Yellow/Start of Red Sector : indicates combustion air supply proved and initial fuel release, but failure to sense flame. Check ignitor, ignition transformer and flame sensor. Check the earth connection to the unit, and to the ignition control and the ignition transformer. Verify that fuel is released by the gas valve.
- E. Green Sector : indicates ignition and flame proved, but subsequent failure. May be caused by change in flame shape or characteristics after valve goes to second stage (full rate) causing failure of flame sensing by ignition control. Check for gas supply problems such as line restriction, etc.

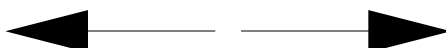

25 - Fault Analysis (Cont'd)

F. End of Green/Start of White Sector : indicates successful ignition but subsequent action of safety controls. Possible causes include flame or flame sensing failure, air supply failure, or opening of Limit Switch (LS2) or Burner Assembly Heatstat (RS). Note that the LS2 and RS switches will reset automatically after opening, although the ignition control must be manually reset.

23.2.6 - No heating; Supply air present; Ignition control not locked-out

- A. Heat Relay contacts RW1 open. Check wiring and coil. Replace if necessary. Failure of heat relay contacts RW2 will allow furnace to function but only on first stage (low rate). Check RW2 and gas valve second stage operator if furnace will not operate at full rate.
- B. Gas Pressure Switch (GS) contacts open. Check wiring and operation of switch. Check that setting of GS is correct for type of gas supplied to unit. If gas line supply pressure is lower than the GS setpoint, contact gas supplier for corrective action.
- C. Limit Switch LS1 open. LS1 must be manually reset to restore operation.

Caution : De-energize all electrical power to unit!

Downflow installations : Remove the supply air access panel. The limit switch assembly is mounted on the condenser partition above the outermost heat exchanger tube. Reset LS1 manually by pressing the reset button on top of the switch.

Sideflow installations : Sizes 090-150 : remove the screws from the rear condenser fan grille and carefully lay the fan assembly to one side. **All models :** remove four screws from the patch plate on the condenser partition and carefully pull the limit switch assembly out and reset the switch as described above. Exercise care not to damage or loosen any wires. Reinstall the limit switch assembly and, **on sizes 090-150**, the condenser fan motor assembly.

D. If voltage is present at ignition control terminals 1 and 9, but the ignition control does not proceed to ignition and/or loc-

kout, replace the ignition control.

23.2.7 - Poor performance; Unit cools or heats but is unable to maintain setpoint.

- A. Dirty air filters. Replace filters at least every 3 months or more often in dirty conditions.
- B. Drive belt slipping. Tighten belt or replace if cracked, glazed, etc.
- C. Cooling/Heating second stage inoperative. Refer to Fault Analysis for general causes of failure to heat or cool.
- D. Cooling only : Low R-22 charge.
- E. Cooling only : Dirty indoor coil surfaces due to dirty or missing filters. Dirty outdoor coil due to dust, leaves, etc.
- F. Cooling only : One motor/compressor of tandem compressor (featured only on certain Capacity units) may fail, causing operation at one half capacity. Check each motor separately for the correct winding resistance and current draw.
- G. Economizer Assembly faulty :
 - i. Damper assembly and/or linkage loose or binding, preventing full range of motion.
 - ii. Damper motor inoperative. To check motor operation, remove screw and pull logic module from damper motor and perform the following steps :
 - a. Verify that internal spring drives motor to fully closed position (i.e. fresh air dampers should be fully closed, return air dampers open).
 - b. Apply 24VAC across terminals TR and TR1. Connect terminals T and T1 with a jumper wire. Damper motor should drive to full open position. Remove jumper wire from terminals T and T1. Damper motor should drive to closed position. Now apply jumper wire across terminals P and P1. Damper motor should drive to full open position. Replace the damper motor if it fails any of these tests.
 - iii. Logic module faulty.

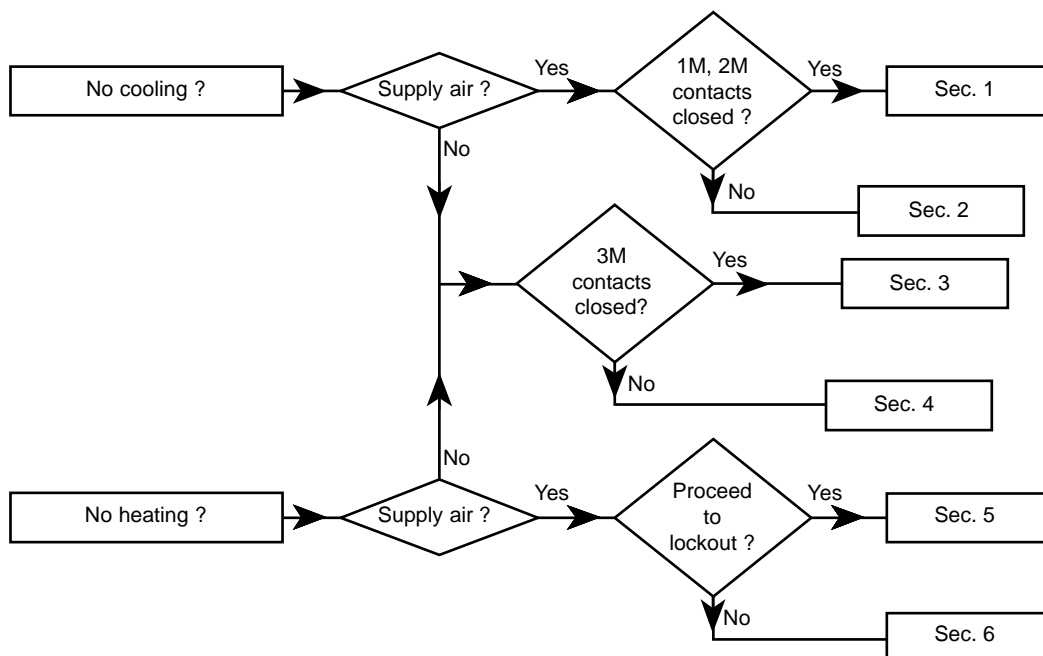

Fig. 39 - Fault analysis flow chart

CUSTOMER INSTALLATION

UNITARY equipment

Simplified Diagram

Notes

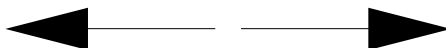



DE-COMMISSIONING DISMANTLING & DISPOSAL

This product contains refrigerant under pressure, rotating parts, and electrical connections which may be a danger and cause injury !
All work must only be carried out by competent persons using suitable protective clothing and safety precautions.



Read the Manual



Risk of electric shock



Unit is remotely controlled and
may start without warning



1. Isolate all sources of electrical supply to the unit including any control system supplies switched by the unit. Ensure that all points of electrical and gas isolation are secured in the OFF position. The supply cables and gas pipework may then be disconnected and removed. For points of connection refer to unit installation instructions.
2. Remove all refrigerant from each system of the unit into a suitable container using a refrigerant reclaim or recovery unit. This refrigerant may then be re-used, if appropriate, or returned to the manufacturer for disposal. **Under NO circumstances should refrigerant be vented to atmosphere.** Where appropriate, drain the refrigerant oil from each system into a suitable container and dispose of according to local laws and regulations governing disposal of oily wastes.
3. Packaged units can generally be removed in one piece after disconnection as above. Any fixing down bolts should be removed and then the unit lifted from position using the points provided and equipment of adequate lifting capacity. Reference MUST be made to the unit installation instructions for unit weight and correct methods of lifting. Note that any residual or spilt refrigerant oil should be mopped up and disposed of as described above.
4. After removal from position the unit parts may be disposed of according to local laws and regulations.

 **York**[®] Europe
YORK INTERNATIONAL

E - TEC - R9803



Manufacturer reserves the right to change specifications without prior notice.